

# **MPS4164**

**64 CHANNEL ELECTRONIC PRESSURE SCANNING  
MODULE**

**INSTRUCTION AND SERVICE MANUAL**

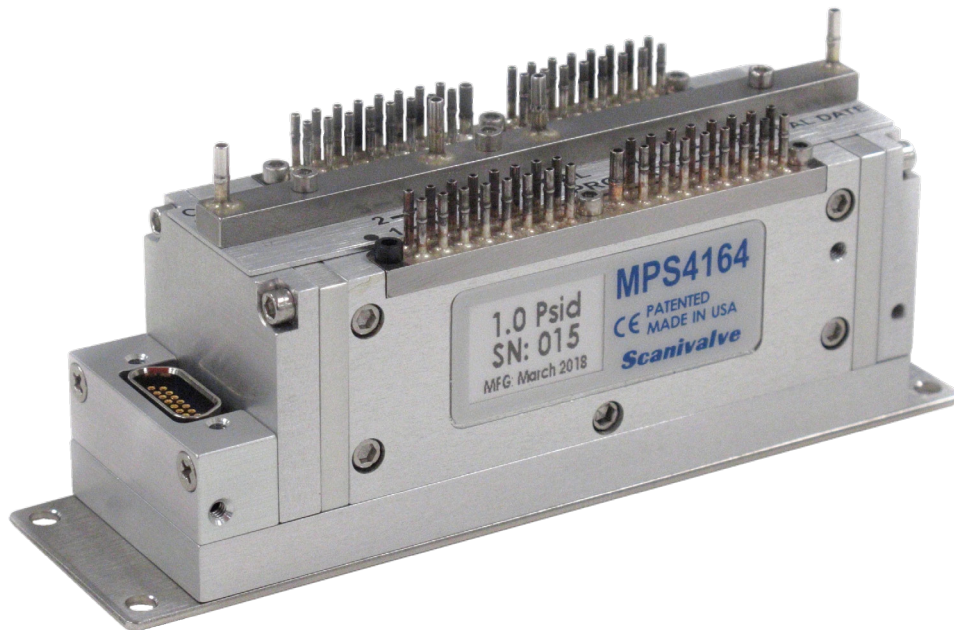

# **Scanivalve**



Instrumentation Devices Srl  
Via Acquanera 29 - 22100 COMO (Italy)  
ph +39 031 525 391- fax +39 031 507 984  
info@instrumentation.it - www.instrumentation.it





# PREFACE

## WARNINGS, CAUTIONS AND NOTES



WARNING

The WARNING! symbol indicates that danger of injury for persons and the environment and/or considerable damage (mortal danger, danger of injury) will occur if the respective safety precautions are not taken.



CAUTION

The CAUTION ! symbol indicates danger for the system and material if the respective safety precautions are not taken.



The ESD note symbol indicates that proper precautions for handling Electrostatic Sensitive Devices needs to be taken when performing the related operation. This includes the use of grounded work surfaces and personal wrist straps to prevent damage to sensitive electronic components.

## WARRANTY

Scanivalve Corporation, Liberty Lake, Washington, hereafter referred to as Seller, warrants to the Buyer and the first end user that its products will be free from defects in workmanship and material for a period of twelve (12) months from date of delivery. Written notice of any claimed defect must be received by Seller within thirty (30) days after such defect is first discovered. The claimed defective product must be returned by prepaid transportation to Seller within ninety (90) days after the defect is first discovered. Seller's obligations under this Warranty are limited to repairing or replacing, at its option, any product or component part thereof that is proven to be other than as herein warranted.

Surface transportation charges covering any repaired or replacement product or component part shall be at Seller's expense; however, inspection, testing and return transportation charges covering any product or component part returned and redelivered, which proves

not to be defective, shall be at the expense of Buyer or the end user, whichever has returned such product or component part.

This Warranty does not extend to any Seller product or component part thereof which has been subjected to misuse, accident or improper installation, maintenance or application; or to any product or component part thereof which has been repaired or altered outside of Seller's facilities unless authorized in writing by Seller, or unless such installation, repair or alteration is performed by Seller; or to any labor charges whatsoever, whether for removal and/or reinstallation of the defective product or component part or otherwise, except for Seller's labor charges for repair or replacement in accordance with the Warranty. Any repaired or replacement product or component part thereof provided by Seller under this Warranty shall, upon redelivery to Buyer, be warranted for the unexpired portion of the original product warranty.

THIS WARRANTY IS IN LIEU OF AND EXCLUDES ALL OTHER WARRANTIES, EXPRESS OR IMPLIED, ARISING BY OPERATION OF LAW OR OTHERWISE, INCLUDING THE IMPLIED WARRANTIES OF MERCHANTABILITY AND FITNESS FOR A PARTICULAR PURPOSE, AND IN NO EVENT SHALL SELLER BE LIABLE FOR INCIDENTAL OR CONSEQUENTIAL DAMAGES.

In the event of a failure:

1) Notify Scanivalve Corporation, Customer Service Department. Include model number and serial number. On receipt of this information, service data or shipping instructions will be forwarded. This may be transacted by telephone or e-mail.

2) On receipt of shipping instructions, forward the product, transportation prepaid. Repairs will be made and the product returned.

3) All shipments should be made via "Best Way". The product should be shipped in the original packing container or wrapped in protective material and surrounded by a minimum of four (4) inches of a shock absorbing material.

**TRADEMARKS ® AND COPYRIGHTS ©**

Scanivalve is a registered trademark of Scanivalve Corporation.

All other brand and product names are trademarks or registered trademarks of their respective companies.

**PACKAGING FOR SHIPMENT**

If the product must be shipped, whether being returned to Scanivalve or relocated to another location it must be packaged properly to minimize the risk of damage. The recommended method of packing is to place the instrument in a container, surrounded on all sides with at least four inches of shock attenuating material such as Styrofoam peanuts.

**IMPORTANT NOTICE**

Please note that the product specifications and other information contained in this manual are subject to change without notice. Scanivalve Corporation makes an effort and strives to provide complete and current information for the proper use of the equipment. If there are any questions regarding this manual or the proper use of the equipment, contact Scanivalve Corporation.

**CONTACT INFORMATION**

If there are any questions or concerns regarding any Scanivalve product please do not hesitate to contact us at the following:

Scanivalve Corp.  
1722 N. Madson Street  
Liberty Lake, WA 99019  
Telephone: (800)935-5151 (509)891-9970  
Fax: (509)891-9481  
scanco@scanivalve.com  
www.scanivalve.com

Scanivalve Corporation is an ISO 9001:2015 certified company.

[INTENTIONALLY LEFT BLANK]

# TABLE OF CONTENTS

---

<b>PREFACE</b>	<b>IV</b>
Warnings, Cautions and Notes	iv
Warranty	iv
Trademarks ® and Copyrights ©	v
Packaging for Shipment	v
Important Notice	v
Contact Information	v
<b>SECTION 1: SPECIFICATIONS</b>	<b>3</b>
General Specifications	3
Environment Specifications	3
<b>SECTION 2: INTRODUCTION</b>	<b>5</b>
General Description	5
Module Configurations	5
Pressure Range	5
Valve Actuation	5
Pressure Sensors	5
Pneumatic Valve	6
Electronics	6
Pneumatic Inputs	7
<b>SECTION 3: INSTALLATION &amp; OPERATION</b>	<b>9</b>
Unpacking	9
Overview	9
Electrical Inputs & Outputs	9
Mounting	11
Environmental Considerations	11
Warm-up	11
Pneumatic Connections	12
Basics of Connecting Input Tubes	12
Pressure Measurement (Px) Ports	12
Calibration (CAL) Port	12
Reference (REF) Port	13
Purge (PRG) Ports	13
Calibrate Mode Control (CAL-PRG CTL) Port	13
Measurement Mode Control (Px CTL) Port	13
Removable Pressure Input Headers	13
Calibration Valve Operation	14
<b>SECTION 4: MPSTCU</b>	<b>16</b>

[INTENTIONALLY LEFT BLANK]



# SECTION 1: SPECIFICATIONS

## GENERAL SPECIFICATIONS

Size (WxHxD)  
(including tubes)

MPS4164	1.145" x 1.690" x 3.515" [29.08mm x 42.93mm x 89.28mm]
MPSTCU	4.295" x 2.350" x 7.647" [109.1mm x 59.7mm x 194.2mm]

Weight

MPS4164	7.6 oz (214g)
MPSTCU	31.3 oz (894g)

(w/scanner & connector)

Inputs (Px)

MPS4164	0.042" [1.067mm] OD (standard) 0.031" [.787mm] OD (optional)
MPSTCU	70 port connector (70MPS series) 0.063" [1.600mm] OD (standard) 0.042" [1.067mm] OD (optional)

Inputs

(Cal, Ref, CTL, PRG) 0.063" [1.600mm] OD

Full Scale Ranges

±4 inH<sub>2</sub>O, ±8 inH<sub>2</sub>O,  
1psid, 5psid, 15psid  
[995.4Pa, 1990.7Pa,  
6.89kPa, 34.5kPa,  
103.4kPa]

Accuracy

4 inH <sub>2</sub> O	±0.20% FS
8 inH <sub>2</sub> O	±0.15% FS
1psid	±0.08% FS
5psid	±0.08% FS
15psid	±0.08% FS

Overpressure (No damage)

4 inH <sub>2</sub> O	25x
8 inH <sub>2</sub> O	15x
1psid	10x
5psid	10x
15psid	5x

Max Reference Pressure 50 psig (350kPa)

Control Pressure Requirements

CPx	65psi
NPx	90 - 120psi

Scan Rate 40kHz (standalone)

Resolution Infinite

Electrical Connector

MPS4164	15 pin MDM 15SL2P
MPSTCU	PT06A-14-19P

Power Requirements +15Vdc @ 120mA  
-15Vdc @ 30mA  
Heater in TCU 20-36Vdc @ 45W

Full Scale Output

Standard	±2.5Vdc
Optional	±5.0Vdc

Sensor Excitation

+5Vdc Constant Voltage  
(Internally Supplied)

## ENVIRONMENT SPECIFICATIONS

Temperature

Operating Temperature 0 to 70°C

TCU with heater -60 to 60°C

TCU with heater/cooling -60 to 125°C

Storage 0 to 80°C

Humidity

Operation 5 to 95% RH, Non-Condensing

Storage 5 to 95% RH, Non-Condensing

Shock & Vibration

MIL-STD-810G, Category 24

Media

Gasses compatible with  
Silicon, Silicone,  
Aluminum and Buna-N

Maximum

Environmental Pressure 100psia (690kPa absolute)

Minimum

Environmental Pressure 0.50psia (3.45kPa absolute)

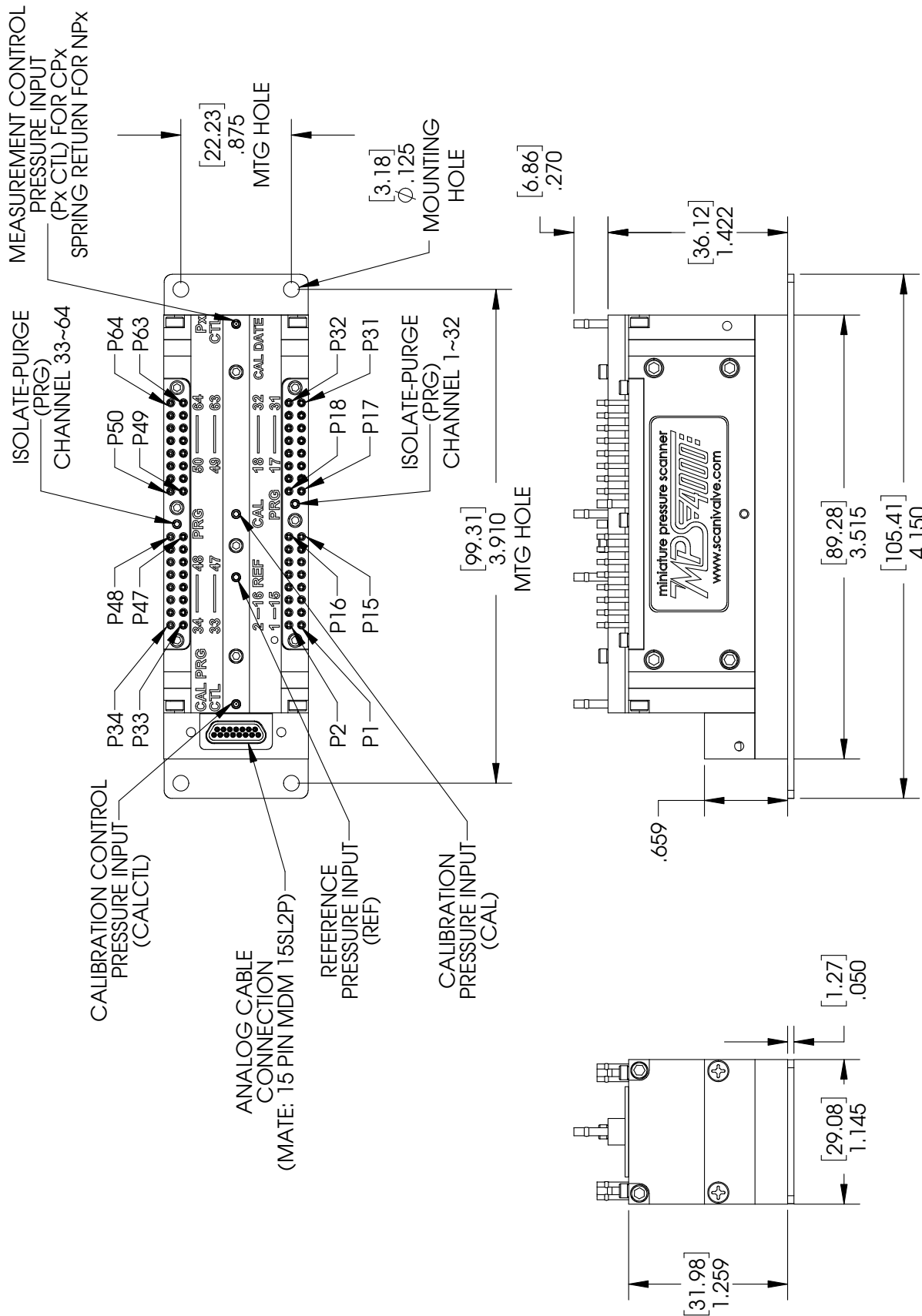

FIGURE 1.1 -MPS4164 DIMENSIONS [INCHES(MM)]

# SECTION 2: INTRODUCTION

## GENERAL DESCRIPTION

The MPS4164 is an analog electronic pressure scanner which can accept 64 pneumatic inputs. Each MPS4164 module incorporates 64 individual piezoresistive pressure sensors. All 64 pressure sensors share a common reference cavity. The MPS4164 electronic pressure scanning module is specifically designed for use in wind tunnels, flight tests, or applications where space is limited and pressures will not exceed 50 psi. The MPS4164 is powered by  $\pm 15\text{Vdc}$ . The output(s) of all 64 sensors are multiplexed to be output serially.

All 64 pressure sensors share a common reference manifold in the center of the module. The MPS4164 module has two pneumatic valves, each servicing 32 pressure sensors. The valve supports four logic states:

1. Measurement
2. Calibrate
3. Purge
4. Isolate

The valve state is selected by applying control pressures in a predetermined and logical order.

Each MPS4164 module has eight (8) 500 ohm platinum RTDs installed. These RTDs are used by a DSM4000 module or RAD4000 data acquisition system to determine the temperature of the MPS module. Additionally, each MPS4164 has a TEDS ID chip installed and programmed to interface with DSM4000 or RAD4000 data acquisition system. This allows automatic identification and configuration of the system on power up. This can be queried by the DSM4000/RAD4000 system to output the serial number, pressure range, position number and calibration date of the MPS scanner.

## MODULE CONFIGURATIONS

The MPS4164 is the analog pressure scanner in the MPS4000 series of pressure scanners. All variants in the series use the same sensors and valves. However, the electronics are different for each, and the overall form factor is slightly different for each model. Because of the interface, form factor and function is different for each variant and they will be covered in separate documents. There are several options that, for the most part, apply to all three variants.

## PRESSURE RANGE

Each MPS module can be ordered in the following pressure ranges:

4 inH <sub>2</sub> O	5psi
8 inH <sub>2</sub> O	15psi
1psi	

## VALVE ACTUATION

There are two options for actuating the valves in the MPS4000 series. Each one is optimal for a specific application. They are:

**Pneumatic "CPx"** - This option places a pneumatic input on each end of the valve. 65psi control pressure applied to each of the ports individually determines the position of the valve. The valve is "bi-stable" meaning once the valve is shifted into a state, it will remain in that state unless an opposite control pressure is introduced, shifting it to the alternate state. This is optimal for any MPS4000 module that will be replacing legacy ZOC33 modules as the 65psi control pressures are common to both.

**Pneumatic "NPx"** - This option uses a pneumatic actuator on one end and a spring on the opposing end. The spring is constantly driving the valve into the measurement, or "Px" mode. This requires no control pressure to scan and collect data. The opposing pneumatic control pressure required is 90-120psi.

## PRESSURE SENSORS

The 64 pressure sensors in the MPS4000 series are mounted in groups of four to custom designed ceramic bases. Sixteen (16) ceramic bases, or "sticks" are RTV'd to a printed circuit board to create a 32 channel set. This architecture allows for a single four-channel sensor "stick" to be replaced at the factory if needed. It also provides patented double isolation from any mechanical stresses that may be present in the assembly.

Each sensor PCB includes four (4) RTD's. The RTD's are used to accurately measure the temperature of the pressure sensors inside of the MPS4164. The temperature of the pressure sensors has a significant effect on their output so compensating for this is a critical function.

For every MPS4000 series module, two sensor circuit boards are mounted back to back in the central housing. The core of the housing is an open volume that is used as a common reference pressure for all 64 channels. The design

places the sensors deep in the center of the module. Being located in the center of the module protects the sensors as much as possible from rapid temperature changes and allows for very accurate temperature compensation.

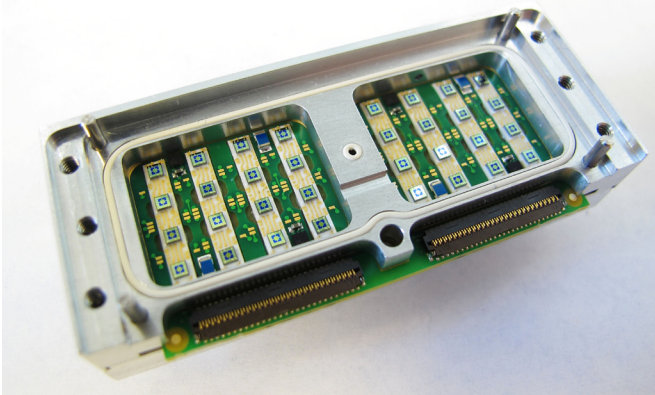

**FIGURE 2-1: PRESSURE SENSOR OVERVIEW**

### **PNEUMATIC VALVE**

A single MPS4000 series module integrates two pneumatic valves, each supporting 32 channels. The valves are located directly under the pressure inputs on each side of the module. The valve supports four pneumatic states in two physical states. In the “measurement mode” pressures are directed in from the measurement inputs to the individual pressure sensors. The other physical state, “calibrate mode” provides three pneumatic states. They are:

1. Calibrate - A single pressure applied to the “CAL” port is directed to the positive side of all 64 transducers.
2. Purge - Purge pressures applied to the two purge inputs are directed out the 64 measurement ports to clear any debris, particulate, or moisture from the input lines.
3. Isolate - The 64 pressure transducers are isolated from the input lines and from the purge pressure.

The valve design is a sliding-type valve. An aluminum shuttle populated with O-rings cycles back and forth between two positions to achieve each of the physical states. An interface between the sliding O-rings and the aluminum stationary portion of the valve is a proprietary compound that is extremely low friction. The O-rings are supported completely to prevent any deformation during a state change. Additionally, the valve shuttle is supported on ball bearings to provide minimal friction and maximum support. This design allows for low actuation forces, minimal “stiction” - meaning the actuation forces do not noticeably increase over time, and minimum wear. Samples of the valve design were tested to over 1,000,000 cycles without any maintenance.

As a subset of the pneumatic option it can either be a spring-driven “NPx” version or a “CPx” bi-directional pneumatic driven version. The advantage of the “CPx” pneumatic version is that it retains the same 65psi control pressure that legacy ZOC33 analog pressure scanner modules used. Two control pressure inputs are used, Px CTL and CAL CTL. In the case of the spring-driven “NPx” version a spring is constantly driving the valves into measurement, or Px mode. This requires no control pressures to be present for measurement and also prevents the valve from unexpectedly or undesirably moving out of measurement mode. The “NPx” version requires 90-120psi control pressures which is common to the DSA line of products that Scanivalve produces.

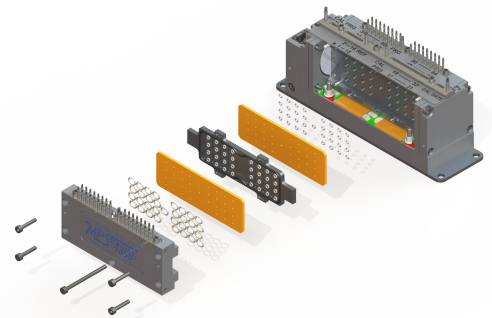

**FIGURE 2-2: PNEUMATIC VALVE EXPLODED VIEW**

### **ELECTRONICS**

The MPS4164 has two unique printed circuit boards and one set of flexible circuits. The Sensor board, as discussed earlier has 32 individual pressure sensors mounted on ceramic bases. Each MPS4164 has two sensor boards. Additionally, there is an “analog” board that handles the sensor excitation, output amplification, and multiplexing of the output. This is located along the bottom of the module under the bottom cover. The 15-pin MDM interface connector is also located on this board.

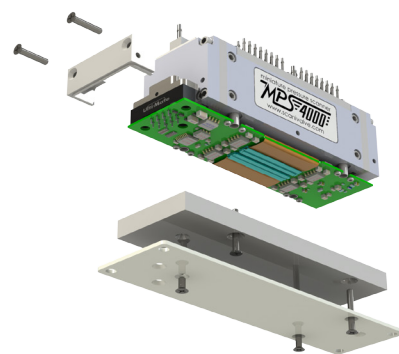

**FIGURE 2-3: ELECTRONICS EXPLODED VIEW**

**PNEUMATIC INPUTS**

For added convenience and flexibility, all pneumatic inputs on the MPS4164 series use removable headers. There are three separate manifolds; two headers for the 64 input ports and a third manifold for the CAL, REF and Control Input(s). The purge supply pressure is also applied through each of the two measurement manifolds. The manifolds are held on with three captive screws each. Under the CAL/REF/CTL manifold is an ID plate that will be free when you remove the manifold. Take care to not lose this plate or the O-rings that are retained by it.

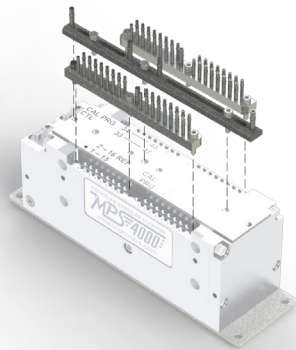

**FIGURE 2-4: PNEUMATIC INPUT HEADERS**

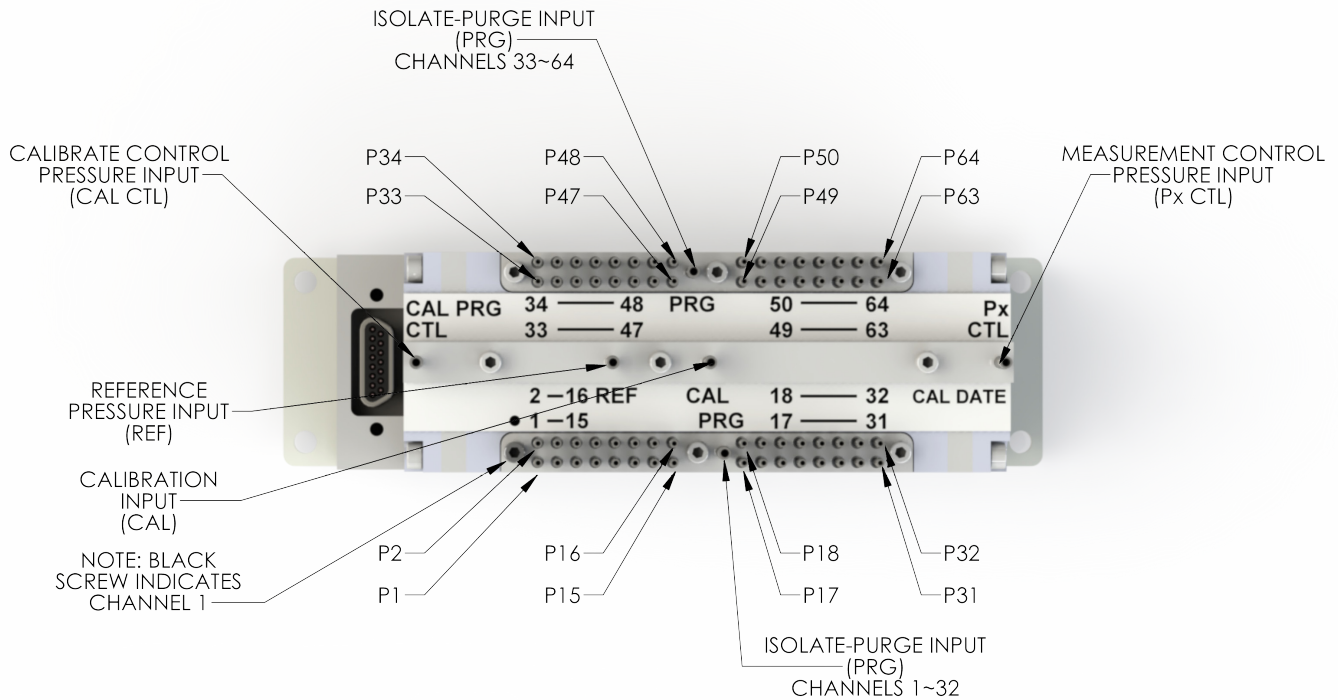

**FIGURE 2-5: PNEUMATIC INPUT IDENTIFICATION**

[INTENTIONALLY LEFT BLANK]



# SECTION 3: INSTALLATION & OPERATION

## UNPACKING

All MPS4164 modules have been extensively tested prior to shipment. All modules are packed to minimize the chances of shipping damage. However, damage can still occur. The customer must inspect the modules and shipping materials for obvious signs of damage. If it is suspected that damage may have occurred, contact Scanivalve Corporation immediately.

Once you have unpacked the module, do an inventory check of the shipment. As a minimum, MPS4164 modules are shipped with the following contents:

1. MPS4164 module
2. Protective case
3. Resource Disk (USB drive)

## OVERVIEW

MPS4164 modules are designed to function best when used with one of Scanivalve Corporation's data acquisition systems; a DSM4000 or RAD4000. All MPS4164 modules will function with older data acquisition systems such as HyScan 2000/1000 as well. They can also be used as a standalone module with another high speed data acquisition system.

## ELECTRICAL INPUTS & OUTPUTS

The Electrical Input and Output wiring is compatible with all other ZOC cable serviced modules. The MPS4164 may be installed into any existing Scanivalve systems without changing configurations. If the MPS4164 is to be used in a custom data system, refer to Figure 3.2.

The user is cautioned to follow safe instrument handling practices when handling the MPS4164 modules. This includes:

- (1) Connect and disconnect all connections to the module with the power off.
- (2) Recommended power input to the module is  $\pm 15\text{Vdc}$ .

Figure 3.2 shows the output connector pin assignments for all of the MPS4100 variations.



**CAUTION!** Not following standard safe instrumentation handling practices could permanently damage the modules.

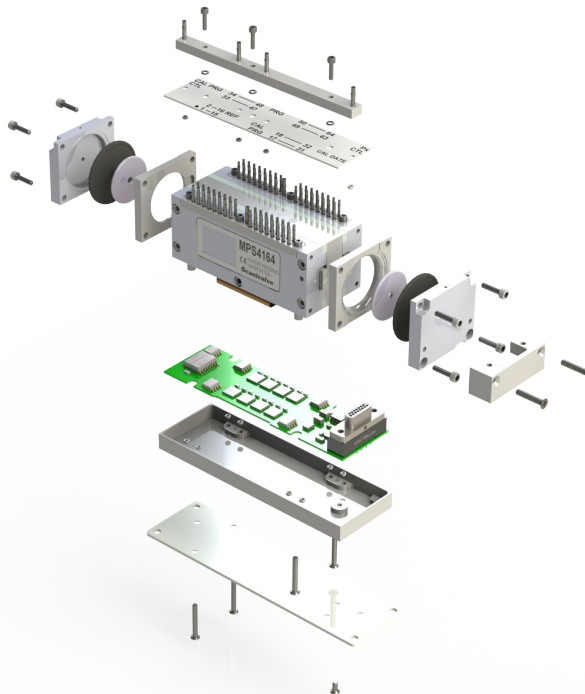

**FIGURE 3.1 - MPS4164 EXPLODED VIEW**

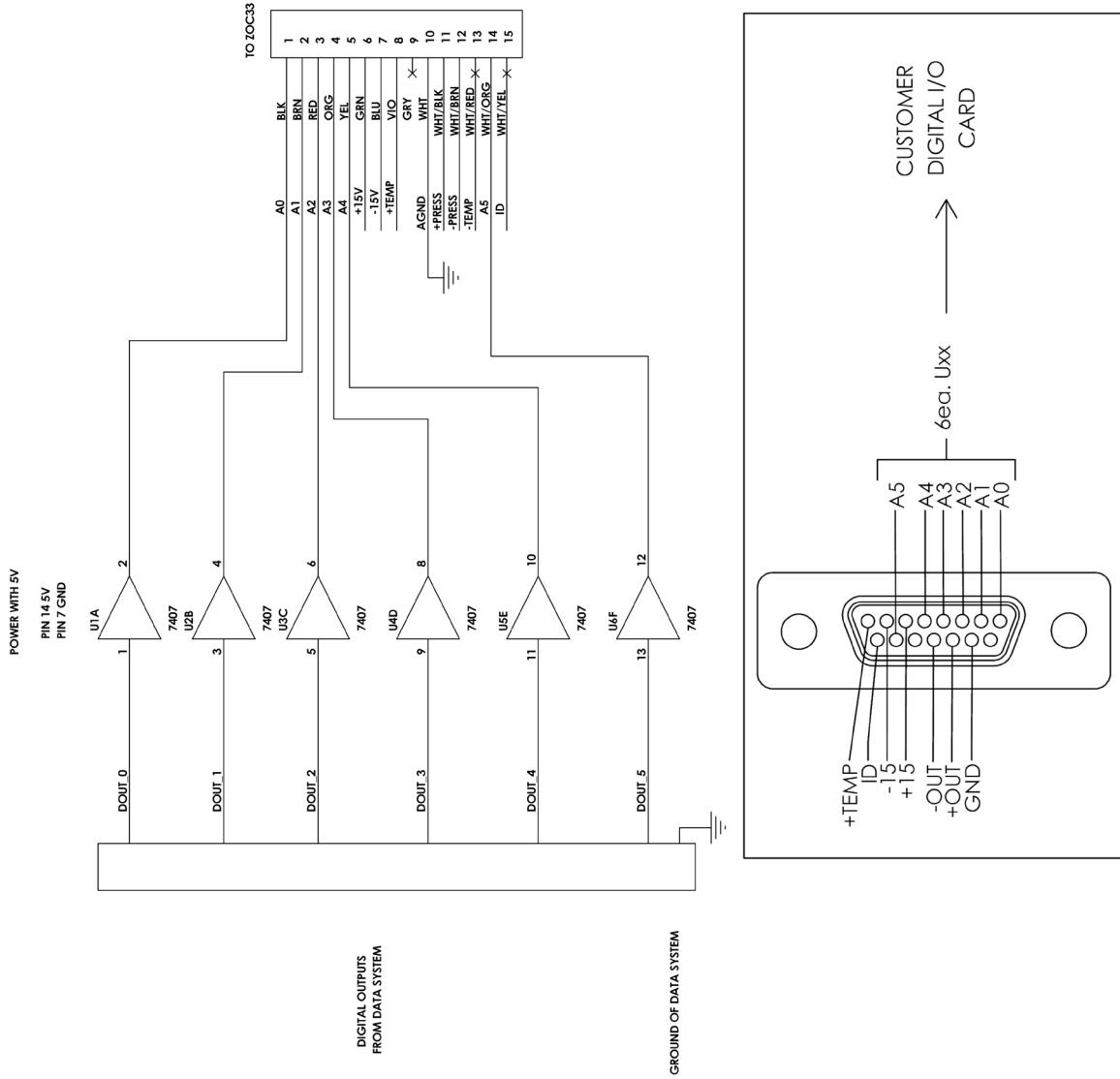
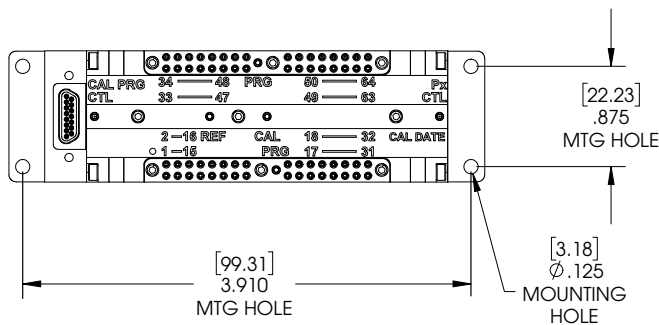

FIGURE 3.2 - MPS4100 ANALOG INTERFACE



### MOUNTING

The MPS4164 includes a stainless steel mounting plate. Using three #2-56 screws it can either be mounted to the bottom of the module or to the side. The mounting plate is 0.060" (1.5mm) thick with four 0.125" (3.1mm) holes in it. See Figure 3-3 for hole spacing, and Figures 3-4 and 3-5 for instructions for attaching the mounting plate to the MPS module. The MPS can be mounted in any orientation.



**FIGURE 3-3: MOUNTING PLATE DIMENSIONS**

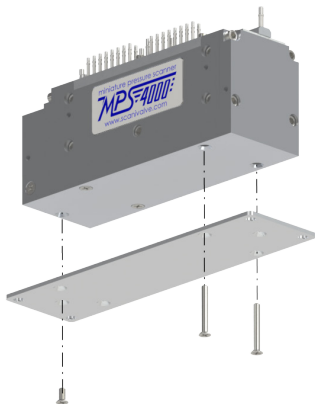

**FIGURE 3-4: MOUNTING PLATE, BOTTOM**

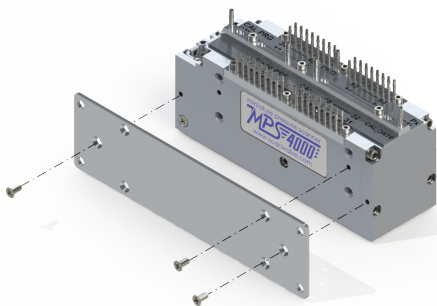

**FIGURE 3-5: MOUNTING PLATE, SIDE**

### ENVIRONMENTAL CONSIDERATIONS

The MPS4000 series scanners are designed to withstand normal industrial, flight test, educational, wind tunnel or similar applications. The module is not water proof and it should be protected from any splash, spray, or mist. If any moisture gets spilled or splashed on the MPS module, wipe it dry immediately to prevent damage to the module.

The MPS module should not be mounted in a location where it may be subjected to extreme temperature shifts or ambient temperatures outside limits defined in "Section 1: Specifications" on page 3. Keep in mind that the internal temperature of the module will run approximately 7°C - 12°C warmer than ambient temperature but this is accounted for in the calibration tables. The temperature specification is with regards to the ambient temperature.

If the MPS module needs to be used in an environment outside of the guidelines above it should be installed in a Thermal Control Unit (TCU). For more information on the MPSTCU, please refer to Section 4 of this manual.



CAUTION! Mounting the MPS module inadequately or in an environment that does not conform to the recommendations can result in permanent damage to the module.

### WARM-UP

Because of the design of the MPS4164, the accuracy is minimally impacted by the device warming up after initially being powered. Figure 3-6 below shows a sample 8"H2O module being powered on. Pressures from 3 channels are shown along with the module temperature. As indicated in the graph, the first 40 minutes of warm up produces the only noticeable change in the pressure readings. The module can take up to 3 hours to fully warm up (in a 25°C ambient environment) but throughout that warm-up the pressure readings are very good. It is recommended that the module be allowed to warm up for 1 hour before collecting data, but this is not mandatory. If time allows, the warm-up period should be extended to 1.5 hours for most applications.

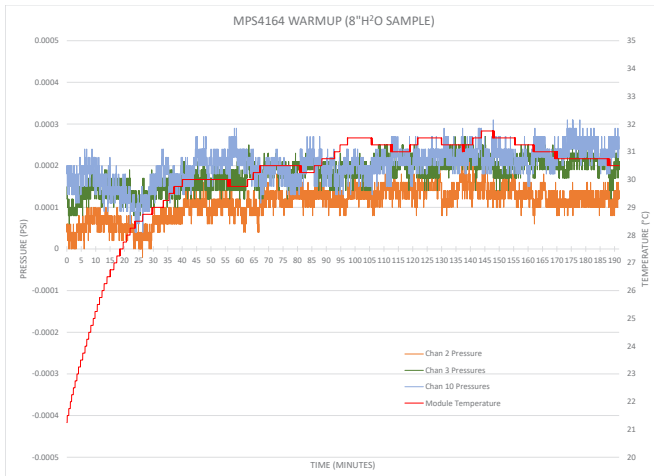

**FIGURE 3-6: TEMPERATURE & PRESSURE THROUGH MODULE WARM-UP**

### **PNEUMATIC CONNECTIONS**

The MPS modules have several different pneumatic connections. All pneumatic inputs are located on the top of the module. There are two basic groups of pneumatic connections types on the module: pressure measurement connection and configuration/support connections. All pneumatic inputs are through one of three removable headers for easy plumbing and system re-configuration. The measurement ports are located along the outer edge of the modules and are identified as 1-32 on one pneumatic header and 33-64 on the opposite pneumatic header. These 64 input ports are directly connected to their own individual pressure transducers within the module. The purge input ports are located on the same pneumatic headers as the measurement input ports. Each purge input port is used as the purge supply feed for purging the input lines on the respective side of the module.

The remaining configuration/support type pressure inputs are all located on the center removable header. These pressure inputs are CAL CTL, REF, CAL, and Px CTL. These ports are used for applying known pressures during calibration, cycling the internal valve between states, and connecting the reference manifold to a known, stable ambient pressure.

The 64 measurement input ports (or Px ports) are available with 0.042" or 0.031" OD tubes. The remaining tubes for the PRG, CAL, REF and CTL inputs will always be 0.063" OD.

For a physical layout of the pneumatic inputs of the MPS4164, refer to "Figure 2-5: Pneumatic input identification" on page 7.

### **BASICS OF CONNECTING INPUT TUBES**

All pneumatic connections are 0.063" or 0.042" OD stainless steel bulged tubulations, or 0.031" OD stainless steel non-bulged tubulations. These tubes are designed to have a tight-fitting plastic tube slid over the OD of the tube. For all low pressure connections (50psi and less) the plastic tubing can simply be slid over the tubulation and the connection is complete. For higher pressure applications, when using Urethane or Vinyl tubing, a helical spring clamp over the OD of the plastic tubing is recommended. The clamp is slid over the tubing and should be placed in position around the apex of the bulge on the tubulation. This helps hold the plastic tubing in place and prevent leaks.

Installing the plastic tubing over the stainless steel tubing can be done much easier by using Scanivalve's special "Tubing push-on tool" P/N: TPOTL-XXX. This tool is offered in a variety of sizes to work for tubing from 0.031" to 0.125" OD.

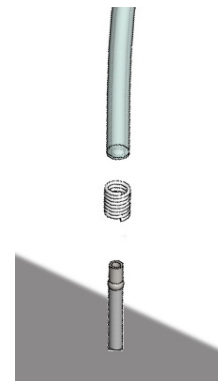

**FIGURE 3-7: TUBULATION CONNECTION WITH HELICAL SPRING CLAMP**

### **PRESSURE MEASUREMENT (Px) PORTS**

Each MPS4164 scanner module has 64 pressure measurement ports, or "Px" ports. They are labeled as 1-64. Each of these ports are connected to a discrete pressure transducer. If any Px ports are not being used, it is recommended that they be plugged to prevent dust or any debris from clogging the port or contaminating the internal calibration valve.

### **CALIBRATION (CAL) PORT**

The MPS module has a single "CAL" port in the center of the middle input header. The "CAL" port provides a means of applying a known calibration pressure to a single port and have it manifolded to the positive side of all of the transducers. During normal operations when the module is in measurement mode this port is internally blocked off. Any pressure applied to the "CAL" port will not reach the transducers unless the internal calibration valve has been configured to direct the calibration pressure to the

transducers. For most low pressure applications (below 15psi) where accuracy is important, the “CAL” port should be connected to a known, stable static location when not being used to apply calibration pressures. This ensures that when a pneumatic zero offset calibration (CALZ) is performed no unwanted offsets are introduced.

#### **REFERENCE (REF) PORT**

The ‘REF’ port ties into a manifold that connects the back side (or negative side) of all transducers together. During most applications, the ‘REF’ port of low pressure modules (below 15 psi) should be routed to a known, stable static location. Typically this “reference” location will be a wind tunnel static port, a static barrel, or in flight test applications - the aircraft static system. This ensures that when a zero offset calibration (CALZ) is performed no unwanted offsets are introduced. During a calibration, positive pressures will be applied through the ‘REF’ port to perform the negative portion of the calibration.

***For applications where an elevated reference pressure will be used, the maximum pressure applied to the REF input is 50psi.***

#### **PURGE (PRG) PORTS**

The purge supply (PRG) port is the input for the pressure that will be used to purge the pressure measurement (Px) lines. ***The supplied purge pressure can be up to 75psi, and must always be clean, dry instrument grade air or nitrogen.*** In order for the purge supply pressure to successfully feed to and clear the Px input lines, the MPS must be in Calibration/Purge mode. This is done by applying control pressure to the “CAL-PRG CTL” port.

Recommended purge pressures are based off of the module’s pressure range and are as follows:

Module Pressure Range	Recommend Purge Pressure
4" H <sub>2</sub> O	1.5 PSI
8" H <sub>2</sub> O	3.0 PSI
1 PSI	10 PSI
5 PSI	25 PSI
15 PSI	75 PSI

#### **CALIBRATE MODE CONTROL (CAL-PRG CTL) PORT**

The “CAL-PRG” control pressure input is used to shift the internal calibration valves into Calibration/Purge mode. In this mode, the positive side of all transducers are tied together and connected to the CAL input, and the individual Px input tubes are manifolded together internally and connected to the purge supply (“PRG”) ports. ***The maximum input pressure for the CAL-PRG CTL input in a “CPx” configured module is 120psi. Clean, dry instrument***

***grade air or nitrogen should be used.***

For modules that are configured with the “CPx” actuation option, the required control pressure to cycle the valve is 60-70psi. Often this can be done with less pressure, but 60psi is recommended for reliable operation of the valve. For “CPx” modules, in normal, low-vibration environments the control pressure does not need to be continuously supplied to this port to hold the valve in the Calibrate mode. Applying the pressure for 2-4 seconds will cycle the valve into the calibrate mode where it will stay until cycled out using the Px CTL port. For high vibration environments, or where it is absolutely critical that the module be held in calibrate mode, it is recommended to continuously supply the pressure to this port to hold the valve in the desired state.

For modules configured with the “NPx” actuation option, the required control pressure to cycle the valve into the “Calibration” mode is 90-120 psi. ***The maximum pressure input for the CAL-PRG CTL in an “NPx” configured module is 120psi. Clean, dry instrument grade air or nitrogen should be used.*** Unlike the “CPx” variation, this pressure must be constantly supplied to keep the module in calibrate mode. When the pressure is vented or released, the internal spring will move the valve back into the default state - “Measurement” mode.

#### **MEASUREMENT MODE CONTROL (Px CTL) PORT**

The “Px CTL” control pressure input is used to shift the internal calibration valve into “Measurement” mode. In this mode, each of the individual transducers are tied to the discrete input (Px) tubes. The CAL and PRG input ports are blocked off. This input port is only present on modules configured with the “CPx” actuation option. ***The maximum input pressure for the Px CTL input is 120psi. Clean, dry instrument grade air or nitrogen should be used.*** To actuate or cycle the valve 60-75psi is recommended. Often this can be done with less pressure, but 60psi is recommended for reliable operation of the valve. Clean, dry instrument grade air or nitrogen should be used.

In normal, low-vibration environments the control pressure does not need to be continuously supplied to this port to hold the valve in the measurement mode. Applying the pressure for 2-4 seconds will cycle the valve into the measurement mode where it will stay until cycled out using the Px CTL port. For high vibration environments, or where it is absolutely critical that the module be held in measurement mode, it is recommended to continuously supply the pressure to this port to hold the valve in the desired state.

#### **REMOVABLE PRESSURE INPUT HEADERS**

All pneumatic inputs to the MPS are through three

removable input headers. Each of the three headers is held in place with three #1-72 screws. A 1/16" Allen/hex wrench fits the screws.

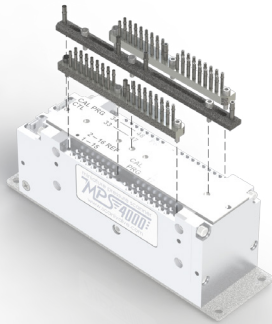

**FIGURE 3-8: REMOVABLE INPUT HEADERS**

The center header is polarized and cannot be installed backwards. However, the two Px input headers are interchangeable and can be installed on the opposite sides. To keep the manifolds unique and identified, the header for inputs 1 through 32 has a single black oxide screw, whereas all of the rest are nickel plated and silver in color. The "correct" location for the black oxide screw is identified on the MPS with a solid black dot. See Figure 3-9 below:



**FIGURE 3-9: HEADER IDENTIFIER MARK**

Be aware, that when the center header is removed the identification plate will no longer be held in place. Like the center header, it is indexed and cannot be installed backwards, but should be handled with care. The O-rings supported in the identification plate should be kept clean, and observed to make sure they stay in place. Replacement or additional headers can be purchased separately as needed.

### **CALIBRATION VALVE OPERATION**

The MPS4164 module has two mirrored calibration valves, each servicing 32 inputs. It is a slider-style valve with the aluminum shuttle riding on ball bearings. The O-rings that move with the valve shuttle ride on a proprietary plastic "bearing plate" that minimizes friction to reduce the actuation force and the wear on the O-rings.

The calibration valve has two physical states, "Measurement" and "Calibrate/Purge." In measurement mode, measurement pressures from the individual input tubes are allowed to pass directly through the shuttle valve to the pressure sensors. In calibrate/purge mode, the measurement pressures from the individual input tubes are blocked off and isolated from the pressure sensors. Instead, the "CAL" input is manifolded and connected to the positive side of all transducers. Additionally, the two "Purge" input lines are connected to the input tubes on their respective valves allowing the user to clear debris or moisture from the input lines by blowing from the module back out to the test article.



**CAUTION!** Do not cycle the valve with pressure supplied to either the CAL or PRG inputs.

It is uncommon, but possible, that while the valve is switching states (between measurement and calibration/purge modes) that any pressure applied to the "CAL" or the "PURGE" ports could "sneeze" past the sealing O-rings and reach the pressure sensor. To prevent risking potential damage to the sensors, the valve should always be cycled with no "CAL" or "PRG" pressure supplied.

Also note that when the valve is in the calibrate/purge state, all 32 measurement inputs on each valve are tied together and connected to the "PRG" input. For most applications this is not a problem, but it will allow "mixing" of measurement pressures between channels. In cases where humid or dirty air is being measured, this "mixing" would provide a flow path in a higher pressure input and back out of a lower pressure input, carrying moisture or debris with it. If it is the case where the module will be held in calibrate/purge mode for an extended period of time while still connected to dirty or humid measurement pressures, a purge pressure great enough to prevent flow from the test article to the scanner should be supplied. For most applications however, this is not needed.

While the valve(s) can be switched between two physical states, functionally it is switching between four pneumatic logic states. The four pneumatic logic states are:

**Operate/Measurement Mode**

This connects each Px input to its associated pressure sensor. The MPS4164 module allows the customer to select one of two banks for input.

**Calibrate Mode**

This mode connects all the pressure sensors to the calibration input.

**Purge Mode**

This mode connects the Px inputs to the pressure sensors and the calibration input. A safe purge pressure can be applied to purge input lines.

Figures 3-10 and 3-11 shows the two logic states:

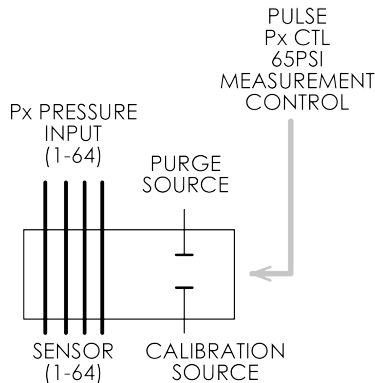

**FIGURE 3-10: PNEUMATIC VALVE LOGIC, OPERATE/ MEASUREMENT MODE**

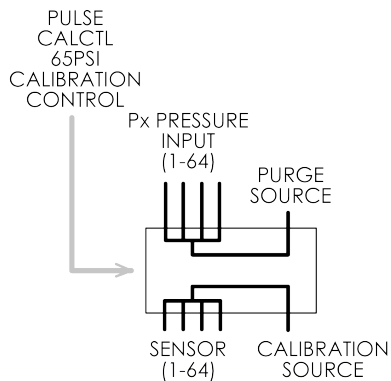

**FIGURE 3-11: PNEUMATIC VALVE LOGIC, CALIBRATE/ PURGE MODE**

Table 3.1 and table 3.2 are module state tables that describe pneumatic logic for each state of the CPx valve. Note that the valve is “bi-stable” meaning that once the valve has been shifted into the desired mode, the control pressures can be removed and the valve will stay in the intended state in a vibration free environment. The valve can be cycled with lower pressures, but 60psi is recommended for reliable operation of the CPx valve. Clean, dry instrument grade air or nitrogen should be used.

In normal, low-vibration environments the control pressure does not need to be continuously supplied to this port to hold the valve in the measurement mode. Applying the pressure for 2-4 seconds will cycle the valve into the measurement mode where it will stay until cycled out using the Px CTL port. For high vibration environments, or where it is absolutely critical that the module be held in measurement mode, it is recommended to continuously supply the pressure to this port to hold the valve in the desired state. The modules have been subjected to shock and vibration testing without control pressures applied. After the conclusion of the test, the valve position was checked and found to still be in the initial state. Again, for critical applications it is recommended that control pressure be supplied continuously.

Table 3.1 - MPS4164/CPx Valve Logic		
Mode	Px CTL	CAL CTL
Operate	65psi	-
Calibrate	-	65psi
Purge	-	65psi
Isolate	-	65psi

Table 3.2 - MPS4164/NPx Valve Logic	
Mode	CAL CTL
Operate	N/A
Calibrate	90-120psi
Purge	90-120psi
Isolate	90-120psi



CAUTION! It is important that all control pressures should be dry, filtered instrument air or nitrogen.



# SECTION 4: MPSTCU

The MPS (Miniature Pressure Scanner) line of Thermal Control Units is available for applications where temperature changes may be great enough to exceed the temperature compensated range of the scanner. Exceeding the compensated temperature range can induce errors in the pressure measurements. See “Section 1: Specifications” on page 7, for more information on the compensated operating temperature range.

MPSTCU applications include flight test, automotive, wind turbine, wind tunnel, and engine tests. When used in a flight test environment, it is recommended that the TCU case be vented.

Each MPSTCU includes a rugged IP-54 rated aluminum enclosure, pneumatic connectors, and a power/data connection. The MPSTCU offers an optional heater circuit which can provide a controlled temperature environment while the MPSTCU is subject to a cold environment (up to -60°C). Additional, the MPSTCU also offers an optional cooling port to provide cooling air when the MPSTCU is subject to temperatures from 60-120°C. When the Cooling Kit is used, 3.0CFM of 23°C air is required while operating the MPSTCU in a 125°C environment.

The MPSTCU uses a single electrical connection for power and data. This connector is an Bendix PT06A-14-19P. For the pin-out diagram of this connector, please refer to figure 4.2 - MPS4164TCU Outline below.

The pneumatic connector is a 70MPS connector. This connector is comprised of 70 ports to facilitate all 64Px inputs and any control pressure inputs. The connector supplied comes standard will 0.063” tubulations. This connector can also be configured with 0.040” tubulations. However, the inputs for PXCTL, CALCTL, CAL, REF, and PRG will remain as 0.063” tubulations.

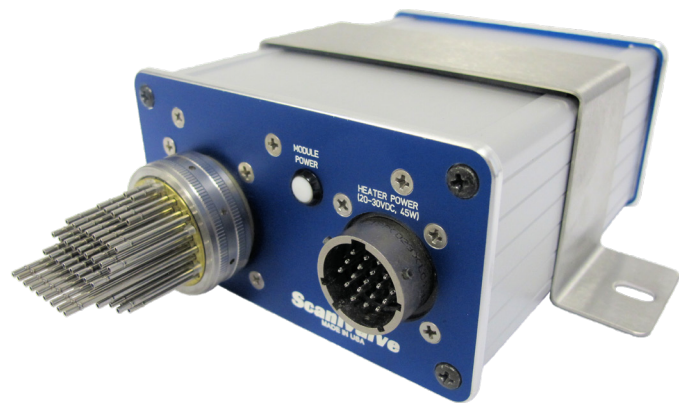
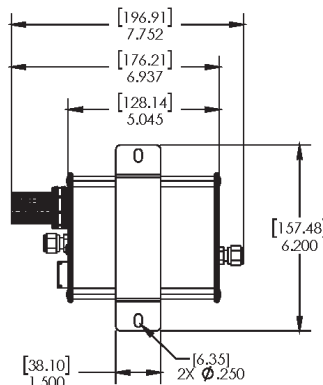
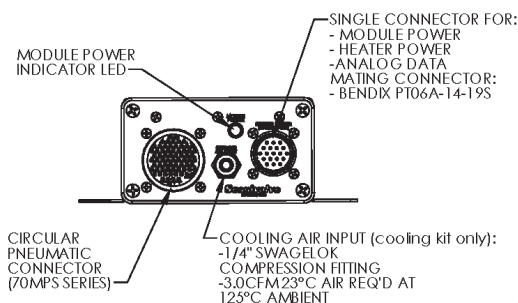

FIGURE 4-1: MPS4164TCU

**NOTES:**

1. ALL UNITS IN INCHES [MM].
2. IP54 RATED (WITH CONNECTORS MATED).
3. VIBRATION TESTED TO MIL-STD-810G, CATEGORY 24.
4. TOTAL WEIGHT: 1.974 LBS [0.895KG] (COOLING VERSION, INCLUDING MATING 70MPS CONNECTOR).
5. TEMPERATURE OPERATING RANGE:  
 -HEATER, NO COOLING: -60°C TO 60°C  
 -HEATER, WITH COOLING: -60°C TO 125°C
6. HEATER POWER DRAW WHILE RUNNING: 20-30VDC @45W.



CONNECTOR PINOUT:

A	ADDRESS 0
B	ADDRESS 1
C	ADDRESS 2
D	ADDRESS 3
E	ADDRESS 4
F	+15 VDC
G	-15 VDC
H	+TEMP
J	-TEMP
K	GND
L	+ OUTPUT
M	- OUTPUT
P	ID
S	ADDRESS 5
U	+20-30 VDC
V	20-30 VDC RTN
N, P, T	NOT USED

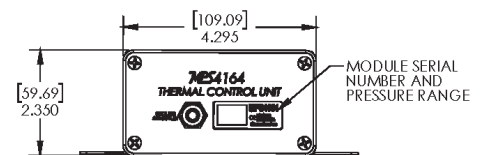
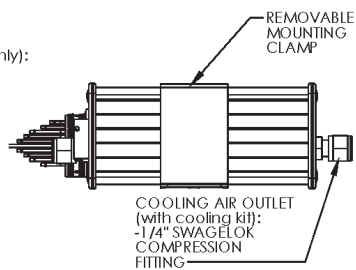

FIGURE 4.2 -MPS4164TCU OUTLINE

[INTENTIONALLY LEFT BLANK]

# **Scanivalve**

**1722 N. MADSON ST.  
LIBERTY LAKE, WA 99019**

**PHONE: 1-800-935-5151  
1-509-891-9970  
FAX: 1-509-891-9481**

**SCANCO@SCANIVALVE.COM  
WWW.SCANIVALVE.COM**

**MPS4164 OPERATION & SERVICE MANUAL  
APRIL 24, 2019**



Instrumentation Devices Srl  
Via Acquanera 29 - 22100 COMO (Italy)  
ph +39 031 525 391- fax +39 031 507 984  
info@instrumentation.it - www.instrumentation.it