

# Third-Generation Compact RDMS™ Telemetry Receiver



## Airborne Accuracy

The Quasonix multi-mode compact RDMS™ telemetry receiver features an extremely sensitive RF downconverter integrated with the company's market-leading ARTM demodulator and bit synchronization in a compact 12 cubic inch flight-ready package. When compared to the competition, RDMS™ offers a remarkable 6 to 8 dB sensitivity advantage. What you choose to do with the extra link margin is up to you. Quasonix is... Reinventing Telemetry™.

**Complete Receiver – RF to Bits** – A single-box solution that accepts RF signals, and delivers baseband clock and data. No external add-ons required.

**Available with Adaptive Equalization** – Reduces dropouts caused by multipath reflections.

**Compact Flight-Ready Package** – Ultra-compact 12 cubic-inch chassis affords flexibility with system integration.

**True Trellis Demodulation in all ARTM Modes** – Provides true trellis detection in all three ARTM modes for optimal demodulation.

**3.5 to 5 dB Improvement in PCM/FM Performance** – Improves BER performance by 3.5 to 5 dB over the best single-symbol demodulators, to within 0.2 dB of the theoretical limit.

**Modulation Index Tracking\* for PCM/FM** – Maintains superior BER performance even if the received signal's modulation index varies by as much as 500%, a breakthrough for tracking legacy analog transmitters (\*patented).

**Phase Noise Compensation** – Optimizes demodulator performance for use with legacy TM packs and transmitters with excessive phase noise.

**Best SOQPSK-TG Detection in the Industry** – RDMS' trellis detection for SOQPSK-TG yields improvements of 2 dB or more over the competition's single-symbol detectors extended LCPC encoding provides all six implemented codes.

**Lowest Noise Figure** – 3.5 dB noise figure bests all other ARTM receivers on the market, hands down.

**Rapid Synchronization** – Synchronizes up to 100 times faster – and maintains sync at lower signal-to-noise ratios – than any other ARTM demodulator. Lower L, upper L, full S, C, or multiple bands available.

Lower L, upper L, full S, C, or multiple bands available

# Compact RDMS Telemetry Receiver Specifications

Receiver	
Type	Dual-conversion superheterodyne
Input RF Frequency	Refer to page 4
Tuning resolution	Tunes in 62.5 kHz increments, to the 70 MHz IF output; after the 70 MHz IF output, receiver tunes in increments of less than 1 Hz
Frequency stability	1 ppm over temperature 1 ppm per year aging
Reference oscillator	20 MHz
Noise figure	3.5 dB (typical), 5 dB (maximum)
LO phase noise, measured at 70 MHz IF output	-115 dBc/Hz @ 1 MHz offset
Maximum RF input	+20 dBm (+10 dBm for C-band)
Available gain (to 70 MHz IF output)	114 dB
Gain control	128 dB control range; User selectable: AGC or MGC (AGC freeze)
AGC time constant	Adjustable, 0.1 ms to 1000 ms
First IF bandwidth	60 MHz (nominal)
IF rejection	> 90 dB
Image rejection	70 dB
RF input impedance	50 ohms

Second IF	
IF frequency	70 MHz
IF output level	-10 to -20 dBm nominal (AGC mode)
IF output impedance	50 ohms
IF bandwidths	250 kHz, 500 kHz, 1 MHz, 2 MHz, 4.5 MHz, 10 MHz, 20 MHz, 40 MHz. Automatic selection based on data rate, with manual override Optional: 70 kHz, 1.4 MHz, 3 MHz, 6 MHz, 14 MHz, 28 MHz

Demodulator	
Demodulator type	ARTM Tier 0 (PCM/FM), ARTM Tier I (SOQPSK-TG), ARTM Tier II (Multi-h CPM) Legacy suite: Analog FM, BPSK, QPSK, Offset QPSK (OQPSK), Asymmetric QPSK (AQPSK), Unbalanced QPSK (UQPSK), Asymmetric Unbalanced QPSK (AUQPSK), Digital PM, Space Time Coding (STC)
Bit Rates	Tier 0: 24 kbps to 23 Mbps in 1 bps steps Tier I: 100 kbps to 46 Mbps in 1 bps steps Tier II: 1 Mbps to 46 Mbps in 1 bps steps STC: 5 Mbps to 22 Mbps in 1 bps steps Legacy: 25 kbps to 23 Mbps in Analog FM, 25 kbps to 23 Mbps in BPSK, 50 kbps to 46 Mbps in QPSK in 1 bps steps

## Demodulator (Continued)

Synchronization time (Average, at BER = 1e-5)	Tier 0: 250 bits, Tier I: 385 bits Tier II: 2,800 bits
Synchronization threshold	Tier 0: -8.0 dB Eb/N0; RF Input (dBm): -118.0 (1 Mbps), -108.0 (10 Mbps) Tier I: -6.0 dB Eb/N0; RF Input (dBm): -116.0 (1 Mbps), -106.0 (10 Mbps) Tier II: -7.0 dB Eb/N0; RF Input (dBm): -117.0 (1 Mbps), -107.0 (10 Mbps)
Sensitivity (BER = 1e-5)	Tier 0: 8.6 dB Eb/N0; RF Input (dBm): -101.4 (1 Mbps), -91.4 (10 Mbps) Tier I: 11.2 dB Eb/N0; RF Input (dBm): -98.8 (1 Mbps), -88.8 (10 Mbps) Tier II: 13.0 dB Eb/N0; RF Input (dBm): -97.0 (1 Mbps), -87.0 (10 Mbps)

## Bit Synchronizer

Input codes	NRZ-L/M/S, BIΦ-L/M/S
Output codes	NRZ-L; or input code unaltered
Data and clock out	TTL or RS-422
Lock detector out	TTL
RSSI	Single 0 – 5 VDC, 50 kHz bandwidth (-37 option required)
Video out	Four (4) wideband outputs, DC to 35 MHz (-37 option required)

## Environmental

Operating Temperature	-20°C to +70°C
Non-operating Temperature	-40°C to +85°C
Operating Humidity	0 to 95% (non-condensing)
Vibration	20 G, 5 Hz to 2 kHz (all axes)
Acceleration	100 G (all axes)
Shock	100 G pk, half-sine, 5 ms (all axes)
Altitude	Up to 100,000 ft.

## Physical

Size / Weight	4.00" x 3.00" x 1.00" / 11 oz.
Connectors	RF input: SMA female IF output: SMA female Baseband: MDM-15 or MDM-37 ("37" option)
Power	28 VDC ± 4 VDC, 750 mA typical
Inrush Current	12 VDC, 3.3 A max (as measured with a Fluke i30s AC/DC current clamp)

# Optional Features

# Compact RDMS Part Numbering Example

- 14** 14 SAW filters £  
(adds 70 kHz, 1.4, 3, 6, 14, and 28 MHz filters)
- EQ** Adaptive Equalizer
- EN** Ethernet Payload
- K7** K7 Viterbi Decoder (k=7, rate 1/2)
- ET** Extended temperature range (-40°C to +85°C)
- WV** Wide operating voltage (15 – 35 VDC)

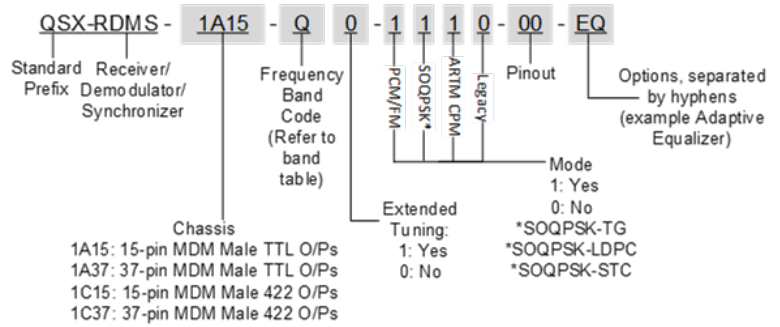

## Compact RDMS Receiver Band Configurations

	200.00 ← Extended	1415.0 ← Extended → 1585.0	1650.0 ← Extended → 1855.0	2185.0 ← Extended → 2500.0	Extended → 5250.0
	400.0 ← Base → 1150.0	1235.5 ← Base → 534.5	1750.0 ← Base → 1850.0	2200.0 ← Base → 2394.0	4400.0 ← Base → 5150.0
	<b>P</b>	<b>Lower L</b>	<b>Upper L</b>	<b>S</b>	<b>C</b>
Freq. Code					
A					
C					
E					
F					
G					
H					
J					
K					
L					
M					
P					
Q					
R					
S					
U					
W					
X					
Y					
Z					

\*Also Available:

- Band Code 7: 70MHz standard range, 0.5 MHz - 20 MHz, 70 MHz extended range
- Band Code T: 2025.0 MHz to 2110.0 MHz standard range

- Frequency Gap
- Standard (Base) Frequency Range
- Extended Frequency Range  
(available by selecting Extended Tuning = 1 in part number)



All Quasonix products are under U.S. Dept. of Commerce jurisdiction. Receivers are categorized as 5A991.  
ISO 9001:2015 Certified | Specifications subject to change without notice.

6025 Schumacher Park Drive West Chester, OH 45069 | 1-513-942-1287 | www.quasonix.com



Instrumentation Devices Srl

Via Acquanera 29 - 22100 COMO (Italy)  
ph +39 031 525 391- fax +39 031 507 984  
info@instrumentation.it - www.instrumentation.it