

## Our range of services:

### Active and passive torque transducers

with cylindrical shaft ends or square / hexagonal connection  
in measuring ranges from 0.02 to 20,000 Nm

For rotating torque transducers, an optional speed or rotation angle measurement can be integrated. The transmission of energy and data is non-contact,

so that the transducers are mechanically robust and are also suitable for high speeds and pulse applications.

### Customized torque transducer

which are designed in cooperation with the customer,  
by e.g. to be integrated into tools.

Through the many years of experience of ETH-messtechnik in this field this is how innovative and competitive products are created.

### Test benches

Individually manufactured according to customer requirements

### Supply and evaluation devices

For sensors for analysis, monitoring of limits,  
shutdown and documentation.

### Accessories

Extensive accessories such as couplings and cables complete our offer.

ETH-messtechnik gmbh was founded in 1987 and has been expanding ever since. Through innovative new developments and optimizations we offer our customers sophisticated products and professional know-how.

Certified according to DIN EN ISO 9001



## Torque Sensors rotating dynamic

7 - 44



cylindrical + square / hexagonal

## Torque Sensors non-rotating static

45 - 66



cylindrical + square / hexagonal

## Torque Sensors customized

67 - 68



customized production





## Analyzers

69 - 88







# CONTENT

## Torque Sensors rotating dynamic Cylindrical Shaft End

	Model	Measurement range (Nm)	Accuracy (%)	Voltage	Current	Frequency	Speed	Angle	Options	Page
	<b>DRVL</b>	± 0 - 0,02 up to ± 0 - 20.000 <b>23 types</b>	0,15 (0,10)  0,10 (0,05)	X	X	X	X		<b>Precision-Torque Sensor</b>  contactless integral signal amplifier electromagnetic compatibility (EMC) , compact, no maintenance	7
	<b>replace DRFL</b>									
	<b>DRFL</b>	see above	0,15 0,10	X	X	X	X		discontinued model, replaced by DRVL	
	<b>DRDL</b>	± 0 - 0,5 up to ± 0 - 5000 <b>16 types</b>	0,1	X		X	X		<b>2-Range Torque Transducer</b>  contactless output signals integral signal amplifier universally applicable no maintenance	11
	<b>DRBK DRBK-A</b>	± 0 - 0,5 up to ± 0 - 1000 <b>11 types</b>	0,5	X	X		X		<b>inexpensive and good DRBK-A with display</b>  very short integral signal amplifier contactless universally applicable no maintenance	15
	<b>DRWPL</b>	± 0 - 0,1 up to ± 0 - 1500 <b>15 types</b>	0,1	X			X	X	<b>Waterproof Torquesensor</b>  integral signal amplifier contactless universally applicable no maintenance	21





# CONTENT

## Torque Sensors rotating Square / Hexagonal Drive Shaft End



	Model	Measurement range (Nm)	Accuracy (%)	Voltage	Current	Frequency	Speed	Angle	Options	Page
	<b>DRFN</b>	± 0 - 0,5 up to ± 0 - 5000 <b>20 types</b>	0,15	X				X	<b>qualified for impulse wrenches</b>  Square drive High accuracy High interference Strain gage technology No service needed	25
	<b>DRFS</b>	± 0 - 1	0,15	X					<b>qualified for impulse wrenches</b>	29
	<b>DRFS-I-w</b>	± 0 - 0,5 up to ± 0 - 20 <b>7/6 types</b>	0,15	x				x	Hexagonal drive High accuracy High interference Strain gage technology No service needed	
	<b>DRFS ¼" -w-S</b>	± 0 - 1 up to ± 0 - 20 <b>7 types</b>		X				X	<b>fixed coupling of transducer and electric screwdriver</b>  No service needed High accuracy Strain gage technology	33
	<b>DRFSK</b>	± 0 - 2 up to ± 0 - 20 <b>6 types</b>	0,15	X				X	<b>Especially suitable for automa- tic screwing machines</b>  <b>Quick-release coupling</b> No service needed High accuracy Strain gage technology	37
	<b>DRFDN</b> <b>DRFDS</b>	± 0 - 0,5 up to ± 0 - 5 <b>4 types</b>	0,15			X		X	<b>Especially suitable for small screwing tools</b>  <b>Digital output</b> No service needed High accuracy Strain gage technology	41

# CONTENT

## Torque Sensors static Cylindrical shaft end / flange

	Model	Measurement range (Nm)	Accuracy (%)	Voltage	Output Voltage Passive Description	Page	
	<b>DRT1</b> <b>DRT2</b> <b>DRT3</b> <b>DRT4</b>	± 0 - 20 ± 0 - 300 ± 0 - 3000 ± 0 - 6000 <b>16 types</b>	0,1	X	X suitable for impulse screwdrivers side load insensitive permanently mountable exchangeable adapters integrated chip for sensor detection	45	
	<b>DRW-K</b>	± 0 - 0,5 up to ± 0 - 20.000 <b>19 types</b>	0,1	X	X fixed cable integrated 100%-control wide range of applications keyway optional	51	
	<b>DRB-I</b>	± 0 - 1 <b>3 types</b>	0,15	X	X <b>suitable for very low torques</b> insensitive by axial and radial forces no maintenance needed single supply voltage	53	
	<b>DRB-II</b>	± 0 - 20 <b>3 types</b>	0,15	X	X integrated overload protection	55	
	<b>DRDML</b> <b>DRDMS</b> <b>DRDMN</b>	± 0 - 20 ± 0 - 20 * ± 0 - 50 <b>19 Variants</b>  *Standard hex	0,15			Cylindrical / square / hexagon with contactless measured value acquisition as complete drive and torque measuring unit for mechanical connection to Maxon transmission	57

## Square drive

	<b>DRN ¼"</b> <b>DRN ⅜"</b> <b>DRN ½"</b> <b>DRN ¾"</b> <b>DRN 1"</b>	± 0 - 20 ± 0 - 63 ± 0 - 200 ± 0 - 500 ± 0 - 1000 <b>17 types</b>	0,15	X	X testing torque wrenches precisely tightening screws measurement of screwings on badly reachable places measuring torque on screwings that are hard to reach	61
	<b>DRN 1½"</b> <b>DRN 2½"</b>	± 0 - 5000 ± 0 - 20.000 <b>7 types</b>	0,15	X	X measuring the friction factor measuring the load on flap valve drives max 2 turns	63
	<b>PH-10</b> <b>PH-20</b>	± 0 - 3000 ± 0 - 10.000  ± 0 - 16.000 ± 0 - 20.000 <b>4 types</b>	0,5	X	X <b>Test Bench for hydraulic torque wrenches</b> adjusting and testing tools before screwing tabulating the relation of working pressure to torque portable test bench	65

# CONTENT

## Analyzer

	<i>Model</i>	<i>Description</i>	<i>Page</i>
	<b>ValueMasterbase</b>	<p>Measurement: torque, speed, angle of rotation, pressure, force or stroke</p> <p>Sockets for 2 sensors</p> <p>Control I/O port with output for PLC</p> <p>Test operation on PC using software supplied by ETH</p> <p>Network connection via Ethernet with scope function</p> <p>Analog output <math>\pm 10</math> V for direction of rotation and drive speed setpoint</p>	69
	<b>GMV2</b>	<p>Measurement of torque, speed and power</p> <p>Measurement modes: tracking, peak (cw/ccw), torque wrench test</p> <p>Menu-driven operation and adjustment</p> <p>Storage for 1000 measurements, 50 programmable parameter sets</p> <p>Power supply 110-240 V</p> <p>RS 232C port, max. 19200 baud, EMC-proof housin</p> <p>Options: look datasheet</p>	77
	<b>GMV2-K</b>	<p>ideal for mobile use in the outdoor area;</p> <p>robust, impact resistant, waterproof</p> <p>USB interface</p> <p>Integrated performance</p>	81
	<b>ValueView 291-1</b>	<p>Resolution 24 bit</p> <p>Sampling rate up to 50 measurements / s</p> <p>Permanent min / max display, tare function</p> <p>Sensor supply</p> <p>+/- full scale input</p> <p>Peak value measurement</p>	85
	<b>Value-View-291-1-003</b>	<p>see above</p> <p>simultaneous measurement of torque and speed</p>	87





## Datasheet

### Torque Transducer

# DRVL

23 torque ranges from  $\pm 0 - 0,02$  up to  $\pm 0 - 20.000$  Nm  
with angle and speed measurement



### Features DRVL

- no maintenance
- contactless
- integral signal amplifier
- single supply voltage
- wide range of applications
- compact
- low moment of inertia
- speed measurement (optional)
- angle measurement (optional)
- Advanced electromagnetic compatibility (EMC)
- adjustable output level for speed- and angle signal (5 - 24 V)
- larger speed range for speed- and angle measurements
- larger input voltage range (10 - 28,8 V)
- Frequency output 10 kHz  $\pm$  5 kHz (RS422)
- optional 0.05 % linearity error

Series DRVL torque transducers are suitable for lab and industrial applications because of their small size and multiple mounting options. As supply voltage and output signal are transmitted without contact, the device can operate continuously with low wear and no maintenance.

These transducers are also available with optional speed and angular measurement for a host of applications. The integrated signal amplifier is powered with 10 - 28,8 V DC and outputs an electrically isolated analog signals of 0  $\pm$  10 V and 10 kHz  $\pm$  5 kHz. The standard version has smooth shaft ends, several types are available with optional keyways (see table).

## Electrical Specifications DRVL

Supply voltage:	10 - 28,8 V DC		
Power consumption:	at Ub 12 V approx. 180 mA (switching converter 2.2 W)		
Rise time 10-90 %:	2 ms (optional 400 $\mu$ s)		
Limit frequency -3 dB:	200 Hz (optional 1 kHz)		
	Voltage output:	Output frequency:	
Voltage output:	0 $\pm$ 10 V	10 kHz $\pm$ 5 kHz (RS422)	
Resolution:	16 bit $\pm$ 0,38 mV	16 bit $\pm$ 0,19 mHz	
Max. output range:	$\pm$ 11 V	$\pm$ 6,3 KHz	
Internal resistance:	100 $\Omega$	–	
Ripple:	< 100 mVss	–	
Nonlinearity/max. measurement error (of full scale)			
DRVL:	0,15 % (optional 0,1 %)	0,15 % (optional 0,1 %)	
DRVL-I to DRVL-VI:	0,1 % (optional 0,05 %)	0,1 % (optional 0,05 %)	
Hysteresis	0,1 %	0,1 %	
Deviation at zero point:	$\leq$ 50 mV	$\leq$ 50 Hz	
Operating temperature:	0 - 60 $^{\circ}$ C		
Compensated temperature range:	5 - 45 $^{\circ}$ C		
Temperature error			
Zero point:	0,02 % / K		
Sensitivity:	0,01 % / K		
Mechanical overload:	100 %		
Internal protection:	IP40		
Connection:	12pin-connector		
<b>Interference emission</b>			
Basic standard	Frequency range		
EN55011 Limit class B	150 kHz - 6 GHz		
<b>Immunity to interference</b>			
Basic standard	Testing accuracy	coupling	Result
EN61000-4-2:2009 Electrostatic discharge (ESD)	4 kV	direct	A
EN61000-4-2:2009 Electrostatic discharge (ESD)	4 kV	indirect	A
EN61000-4-3:2009 Electromagnetic fields	10 V/m	indirect	A
EN61000-4-4:2009 Bursts	2 kV	indirect	A
EN61000-4-5:2005 Surge voltages	1 kV	direct	B
EN61000-4-6:2009 Conductor-borne RF disturbances	10 V/m	indirect	A
EN61000-4-8:2005 Power frequency magnetic fields	30 A/m	indirect	A
A: Deviation of outputs during the test < 0.3 % of full scale			
B: Deviation of outputs during the test > 0.3 % of full scale			

	Speed option (n)	Angle option (w)
Max rev.:	$\leq$ 37.000 min <sup>-1</sup> *	$\leq$ 20.000 min <sup>-1</sup> *
Output:	TTL or over voltage on pin 5 V < U < 24 V	
Impedance:	22 $\Omega$	22 $\Omega$
I <sub>max</sub> :	20 mA	20 mA
Pulses/rev.:	60	2 x 360
Resolution:	--	1 $^{\circ}$
Phase shift:	--	Channel A 90 $^{\circ}$ at right spin of propulsion side
* The values are valid for ETH test cables $\leq$ 10 m, the maximum permissible speed of the sensor must be observed.		

## Mechanical Dimensions DRVL

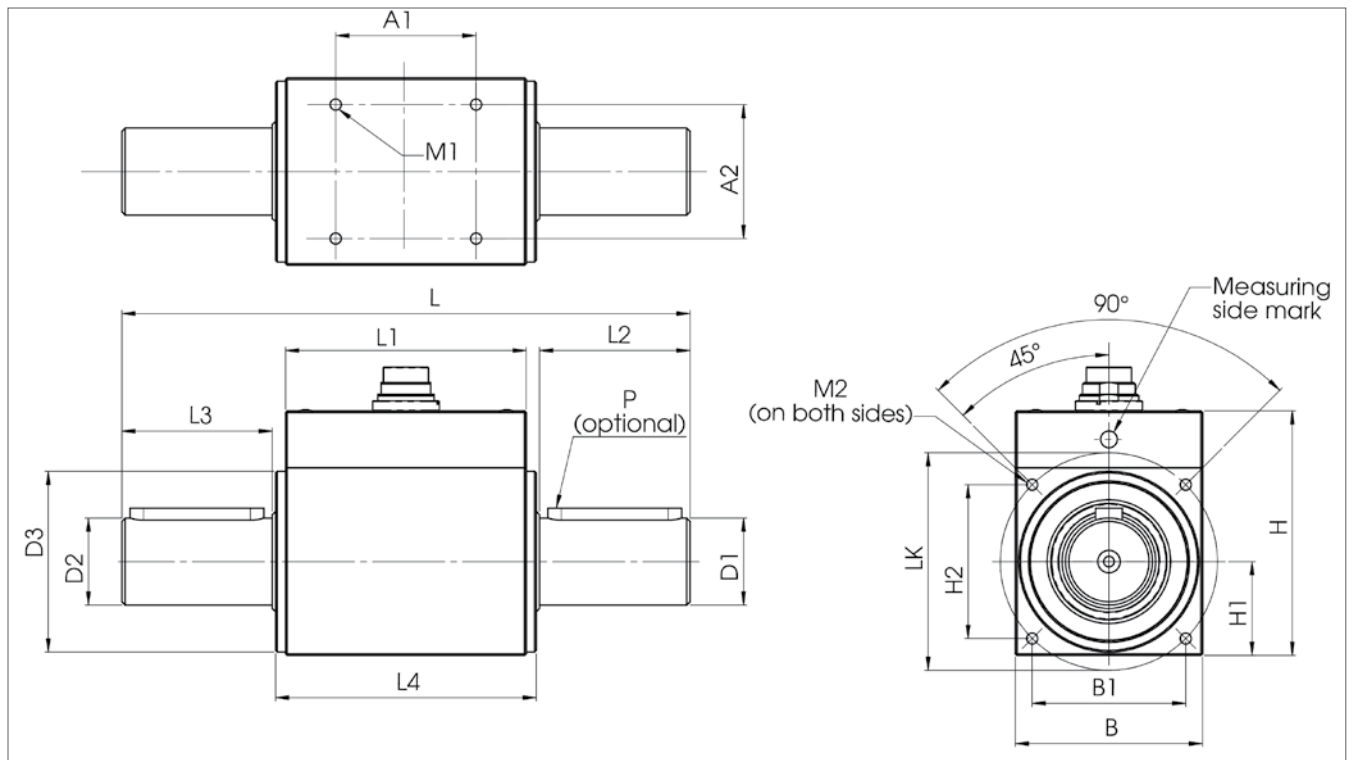

Model	DRVL	DRVL-I	DRVL-Ib	DRVL-II	DRVL-III	DRVL-IV	DRVL-V	DRVL-VI	
Torque Ranges (±0 - ... Nm)	0,02 0,05 0,1	0,05 0,1 0,2 0,5 1	2	1 2 5 10	5 10 20 30 50	50 100 150 200 300	500 1000 1300 1500	2000 3000 4000 5000	10.000 15.000 20.000
<b>Dimensions:</b> (other ranges upon request; General tolerances DIN 2768-m)									
L (mm)	82	89	95	110	145	170	270	320	355
B (mm)	32	28		36	42	56	88	105	168
B1 (mm)	24	(→ LK)		(→ LK)	(→ LK)	(→ LK)	(→ LK)	(→ LK)	--
H (mm)	47	54		58	58	73	104	121	185
H1 (mm)	14	14		18	21	28	44	52,5	84
H2 (mm)	22	(→ LK)		(→ LK)	(→ LK)	(→ LK)	(→ LK)	(→ LK)	--
∅ D1 g6 (mm)	3	8	8	10	15	26	45	70	110
∅ D2 g6 (mm)	3	5	6	10	15	26	45	70	110
∅ D3-0,1 (mm)	15	27		32	38	54	80	--	--
∅ LK ± 0,1 (mm)	(→ B1/H2)	32		38	46	65	98	--	--
L1	63	62		68	79	72	84	95	121
L2	7,5	10	14	18	30	45	85	110	115
L3	7,5	11	14	18	30	45	85	110	115
L4	67	66		72	83	78	90	--	--
A1	50	40		56	60	42	46	75	91
A2	24	22		24	32	40	70	85	138
M1	M2,5 x 5 deep	M3 x 5 deep		M3 x 6 deep	M3 x 6 deep	M4 x 8 deep	M6 x 12 deep	M8 x 16 deep	M10x16 deep
M2	M2,5 x 5 deep	M3 x 6 deep		M3 x 6 deep	M3 x 6 deep	M4 x 8 deep	M6 x 12 deep	--	--
P (DIN 6885) optional	--	--		2xA3x3x14	2xA5x5x25	2xA8x7x40	4xA14x9x80	4xA20x12x100	--
Weight (g)	200	170		340	600	1300	4500	11.500	33.000
n max (min <sup>-1</sup> )	20.000	37.000		26.000	19.000	13.500	7900	6300	4000

## Technical Specifications DRVL

Model	Torque range (±0 - ... Nm)	Spring constant C (Nm/rad)	Mass moment of inertia J (g x cm <sup>2</sup> )	Rated axial load (N) *	Rated radial load (N) *
DRVL	0,02	16	7	35	30
	0,05	16	7	35	30
	0,1	16	7	35	30
DRVL-I	0,05	20	10	105	2
	0,1	35	10	140	3
	0,2	35	10	140	3
	0,5	45	10	160	4
	1	90	10	210	7
	2	135	10	210	13
DRVL-Ib	1	255	30	630	10
	2	255	30	630	10
	5	715	30	725	25
	10	1320	30	725	50
DRVL-II	5	960	100	1200	15
	10	2115	100	1300	30
	20	3955	100	1300	60
	30	5340	105	1300	100
	50	6700	105	1300	155
DRVL-III	50	17 x 10 <sup>3</sup>	775	1800	125
	100	30 x 10 <sup>3</sup>	785	1800	215
	150	45 x 10 <sup>3</sup>	800	1800	340
	200	54 x 10 <sup>3</sup>	810	1800	450
	300	67 x 10 <sup>3</sup>	840	1800	650
DRVL-IV	500	260 x 10 <sup>3</sup>	9935	4150	650
	1000	387 x 10 <sup>3</sup>	10.140	4150	1275
	1300	429 x 10 <sup>3</sup>	10.285	4150	1650
	1500	449 x 10 <sup>3</sup>	10.380	4150	1700
DRVL-V	2000	1,45 x 10 <sup>6</sup>	63 x 10 <sup>3</sup>	4800	1950
	3000	1,85 x 10 <sup>6</sup>	64 x 10 <sup>3</sup>	4800	2930
	4000	2,10 x 10 <sup>6</sup>	64 x 10 <sup>3</sup>	4800	3880
	5000	2,30 x 10 <sup>6</sup>	65 x 10 <sup>3</sup>	4800	4000
DRVL-VI	10.000	8,20 x 10 <sup>6</sup>	440 x 10 <sup>3</sup>	11.800	8895
	15.000	10,45 x 10 <sup>6</sup>	448 x 10 <sup>3</sup>	11.800	9830
	20.000	11,80 x 10 <sup>6</sup>	546 x 10 <sup>3</sup>	11.800	9830

\* The values for axial and radial load apply to the non-fixed case

## Ordering code system

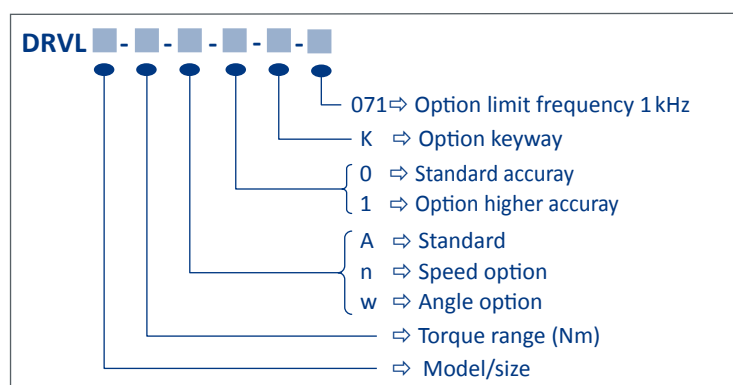

## Available Accessories

Supply and display unit: GMV2  
ValueMaster<sub>base</sub>

Cables  
Couplings

## Datasheet

### 2-Range Torque Transducer

# DRDL

16 sensor versions from  $\pm 0 - 0,5$  up to  $\pm 0 - 5000$  Nm  
with speed and angular measurement



### Features

- **2 torque ranges**
  - 1/10 - 1/2 of the 1st measuring range
- integral signal amplifier
- low moment of inertia
- single supply voltage
- wide range of applications
- contactless output signals
- no maintenance
- compact
- speed measurement (option)
- angle measurement (option)

The dual-range torque sensor is perfectly suited for use as a test-bench sensor. It is custom-built to measure **two ranges synchronously without change-over (!)**: both peak torque and operating torque are very accurately measured. A 100 % overload protection for the large load offers additional protection against transient overloads.

As the supply voltage and measurement output are transmitted without any physical contact, the device can operate continuously with negligible losses and without the need for maintenance.

The integrated measurement amplifier outputs an analog, electrically isolated 0 to  $\pm 10$  V signal per measurement range for a 12 V DC supply voltage.

The advantages of this sensor are its high torque bandwidth as well as in the reduction of change-over time and conversion costs.

The sensor is suited for measurements on electric motors, friction measurements in gearboxes, performance measurements, generator tests and automated inspection applications.

## Technical Specifications DRDL

Supply voltage:	12 V DC $\pm$ 10 %
Current consumption:	< 200 mA
Rise time 10-90 %:	2 ms
Limit frequency -3 dB:	200 Hz
Voltage output:	0 to $\pm$ 10 V
Internal resistance:	100 $\Omega$
Ripple:	< 100 mV <sub>ss</sub>
Nonlinearity:	< 0,1 %
Hysteresis:	< 0,1 %
Deviation at zero point:	$\leq \pm$ 100 mV
Max measurement error:	0,1 % (FS / of full scale)
Operating temperature:	0 - 60 °C
Compensated temperature range:	5 - 45 °C
Temperature error	
Zero point:	0,02 % / K
Sensitivity:	0,01 % / K
Mechanical overload:	100 %
Internal protection:	IP40
Connection:	12pin- connector
Factory calibration Right-/ left load in 25% steps. Special calibration on request.	
<b>EMV Immunity for interference (DIN EN 61326-1 / EN 61000-6) *1</b>	
Enclosure	Severity
HF line interference	
150 kHz - 80 MHz (AM)	10 V
ESD (Electrostatic discharge)	Air 8 kV / Contact 4 kV
Enclosure	
Electromagnetic Field	
80 MHz - 1000 MHz (AM)	10 V/m
150 kHz - 80 MHz (AM)	20 V/m
Leads - Connection Cable	
Burst (fast transients)	2 kV
*1 Severity / Criterion: industrial environment; Cable length $\leq$ 30 m. Application not outside buildings.	
<b>Interference Emission (EN 55011)</b>	
Disturbance Voltage (electromagnetic Disturbances)	Class B (150 kHz - 30 MHz)
Radiated Emission (electromagnetic Disruption axis)	Class B (30 MHz - 1000 MHz)

Speed Option (n)	
max. rev.:	10.000 min <sup>-1</sup> *
Output:	open-collector
Internal pull up:	10 k $\Omega$ (5 V Level)
External pull up:	24 V max.
I <sub>max</sub> :	20 mA
Pulses / rev.:	60
* with additional external wiring 20.000 min <sup>-1</sup> (or speed max.)	

Angle Option (w)	
max. rev.:	3000 min <sup>-1</sup> **
Output:	open-collector
Internal pull up:	10 k $\Omega$ (5 V Level)
External pull up:	24 V max.
I <sub>max</sub> :	20 mA
Pulses / rev.:	360
Resolution:	1°
Phase shift	Channel A 90° at right spin of propulsion side.
** with additional external wiring 15.000 min <sup>-1</sup> (or speed max.)	

## Mechanical Dimensions DRDL

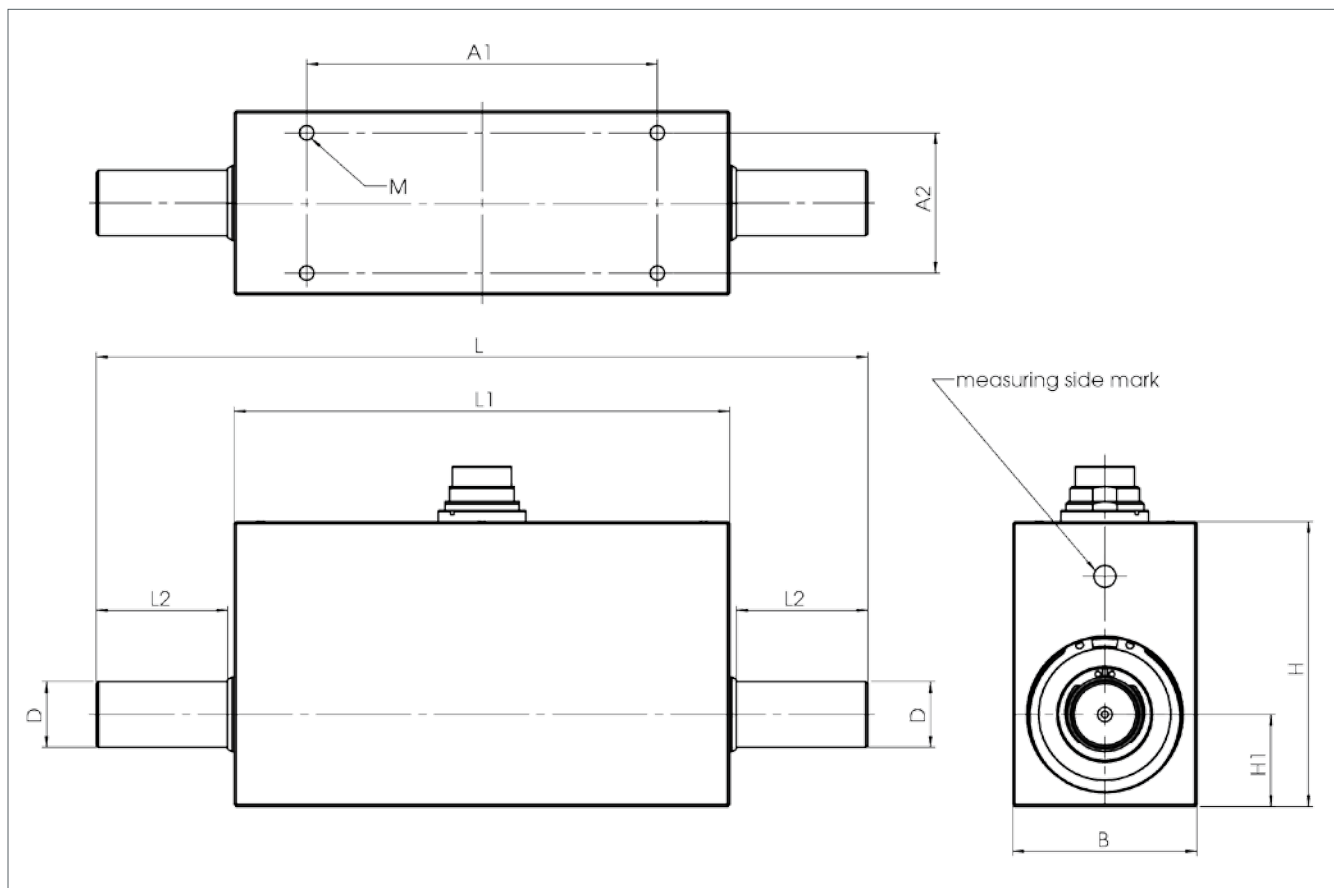

	DRDL-I	DRDL-II	DRDL-III	DRDL-IV	DRDL-V
1. Torque Range (±0 - ... Nm)	0,5   1   2	5   10   20   50	50   100     200   300	500   1000   1500	2000   3000     4000   5000
2. Torque Range	selectable when ordering (1/10 to 1/2 of the 1st range) - other measuring ranges on request! -				
L (mm)	108	176	184	280	352
L1 (mm)	76	113	92	107	129
L2 (mm)	14	30	45	85	110
B (mm)	44	42	60	97	125
H (mm)	65	65	75	106	136
H1 (mm)	20	21	28	45	58
D g6 (∅ mm)	6	15	26	45	70
A1 (mm)	60	80	70	70	105
A2 (mm)	32	32	45	70	100
M	M3 x 6 deep	M4 x 8 deep	M5 x 10 deep	M6 x 15 deep	M8 x 16 deep
Weight approx. (g)	420	800	1500	5600	14.000
Speed max. (min <sup>-1</sup> )	36.000	19.000	13.500	7900	7900

General tolerances DIN 2768-m

## Mechanical values and load limits DRDL

Size	Measuring range (± 0 - ... Nm)	spring constant C (Nm/rad)	Mass Moment J (g • cm <sup>2</sup> )			Permitted Axial load (N) *	Permitted Radial load (N) *
			Total	Drive side	Measuring side		
I	0,5	32	16	16	0,6	120	1,8
	1	59	18	17	1,7	280	3,4
	2	130	18	17	1,7	349	6,9
II	5	508	126	95	32	880	10
	10	1183	127	95	32	1300	20
	20	2318	128	96	32	1300	40
	50	4322	130	97	33	1300	103
III	50	9488	905	565	340	1820	77
	100	20.354	912	569	343	1820	153
	200	37.724	927	576	351	1820	309
	300	49.069	946	586	360	1820	461
IV	500	161.773	10.677	5994	4683	4560	414
	1000	280.730	10.813	6062	4751	4560	829
	1500	350.925	10.975	6143	4832	4560	1199
V	2000	881 x 10 <sup>3</sup>	71.566	38.833	32.733	5650	6550
	3000	1176 x 10 <sup>3</sup>	71.970	39.035	32.935	5650	9765
	4000	1385 x 10 <sup>3</sup>	72.430	39.265	33.165	5650	11.300
	5000	1535 x 10 <sup>3</sup>	72.931	39.516	33.415	5650	11.300

\*The values for axial and radial load refer to the non-fixed housing.

## Ordering Code

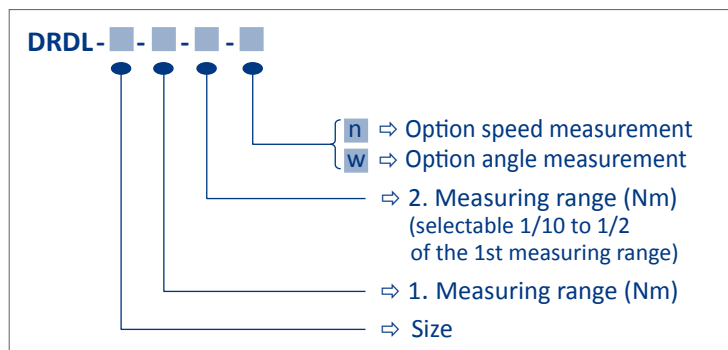

## Available Accessories

Analyzer ValueMaster<sub>base</sub>  
Cables  
Couplings



## Datasheet

### Torque Transducer

# DRBK + DRBK-A

11 torque ranges from  $\pm 0 - 0,5$  up to  $\pm 0 - 1000$  Nm



### Features

- Low-Cost Torque transducer
- Current output and voltage output
- Very short
- Measurement accuracy:  $\leq 0.5\%$  of full scale
- Contactless transfer of measurement signal
- Proven strain gage technology
- Integrated signal amplifier
- Single power supply
- wide range of applications
- Optional speed measurement

### Extra Features DRBK-A

- Simultaneous speed/torque indication
- 4-segment display with sign
- Peak mode (clockwise only)
- Indication area on LCD display 30 x 11 mm
- Speed indication updated 1x sample/second
- Torque updated 1,000 samples/second

The DRBK series torque transducers, with their compact dimensions and versatility, are ideal for torque measurements for lab and industrial applications

As supply voltage and output signal are transmitted without contact, the device can operate continuously with low wear and no maintenance.

These transducers are also available with speed measurement for a host of applications.

Series DRBK-A torque transducers are custom made for applications where an extra analyzer should not be used or is not needed.

Production monitoring data can be clearly displayed at very small cost!

## Technical Specifications: DRBK + DRBK-A

Supply voltage:	11,5 to 30 V DC
Current consumption:	approx. 200 mA
Rise time 10-90 %:	1 ms
Limit frequency -3 dB:	1 kHz
Voltage output:	0 to $\pm 5$ V
Internal resistance:	100 $\Omega$
Current output:	10 $\pm$ 8 mA    Burden max 500 $\Omega$
Ripple:	< 50 mVss
Nonlinearity:	< 0,3 %
Hysteresis:	< 0,3 %
Deviation at zero point:	$\leq \pm 100$ mV / $\pm 200$ $\mu$ A
Max. measurement error	0,5 % (FS / of full scale)
Operating temperature:	0 - 60 $^{\circ}$ C
Compensated temperature range:	5 - 45 $^{\circ}$ C
Temperature error	
Zero point:	0,05 % / K
Sensitivity:	0,02 % / K
Mechanical overload:	100 %
Internal protection:	IP40
Connection:	12pin- connector

### EMV Immunity for interference (DIN EN 61326-1 / EN 61000-6 ) \*1

Enclosure	Severity	Criterion
HF line interference 150 kHz - 80 MHz (AM)	3 V	A
(ESD) Electrostatic discharge	Air 8 kV	A
	Contact 4 kV	A
Enclosure		
Electromagnetic Field		
80 MHz - 1000 MHz (AM)	10 V/m	A
80 MHz - 2700 MHz (AM)	10 V/m	A
Leads - Connection Cable		
Burst (fast transients)	2 kV	A
Surge voltage (Surge)	1 kV	B
Interference Emission (EN 61326-1 / EN 55011)		
Disturbance Voltage (Electromagnetic Disturbances)	-	Class B (150 kHz - 30 MHz)
Radiated Emission (Electromagnetic Disruption axis)	-	Class B (30 MHz - 1000 MHz)

Speed Option (n) only DRBK *2	
max. rev.:	10.000 min <sup>-1</sup> *3
Output:	Open-Collector
Internal pull up:	4,7 k $\Omega$ (5 V level)
External pull up:	24 V max. / 20 mA
Pulses/rev.:	60

\*1 Severity / Criterion: industrial environment;  
Cable length  $\leq$  30m.  
Application not outside buildings.

\*2 standard on DRBK-A

\*3 by proper external connections til speed max.

## Mechanical Dimensions DRBK

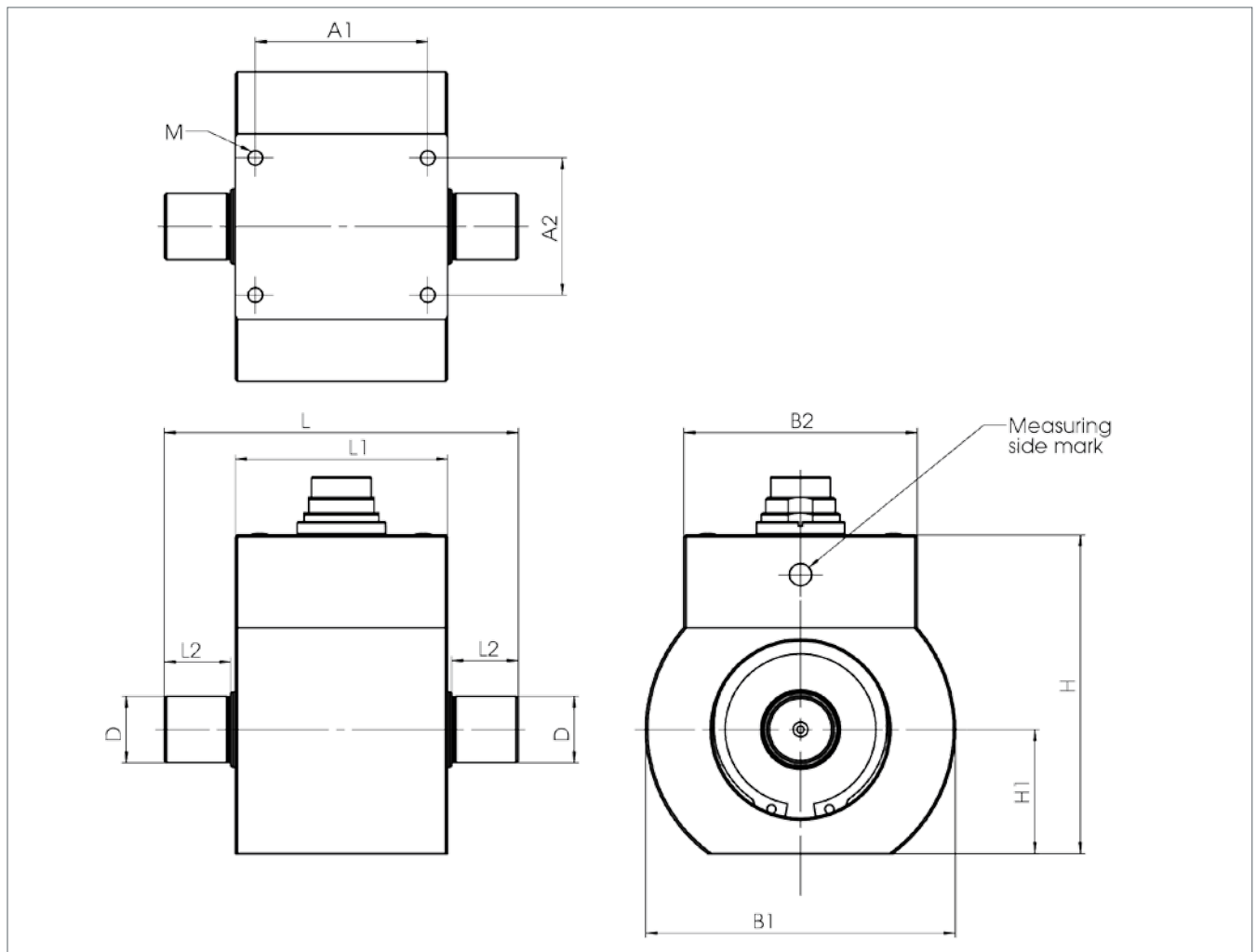

## Sizes DRBK

Type:		0	I	II	III
Torque Ranges: ( $\pm 0 - \dots$ Nm)		0,5   1   2	5   10   20	50   100   200	500   1000
Dimensions:					
L	(mm)	66	80	90	120
$\varnothing$ B1	(mm)	45	70	75	105
B2	(mm)	45	53	53	76
H	(mm)	56	72	77,5	97,5
H1 $\pm 0,05$	(mm)	18	28	30	40
$\varnothing$ D g6	(mm)	6	15	24	40
L1	(mm)	42	48	52	65
L2	(mm)	10	15	18	26
A1	(mm)	33	39	42	50
A2	(mm)	20	31	35	55
M		M3 x 5 deep	M4 x 6 deep	M4 x 6 deep	M5 x 10 deep
General tolerances DIN 2768 - m					
Weight approx.:	(g)	230	550	850	2450
Speed max.:	(min <sup>-1</sup> )	20000	18000	16000	9000

## Mechanical Dimensions DRBK-A

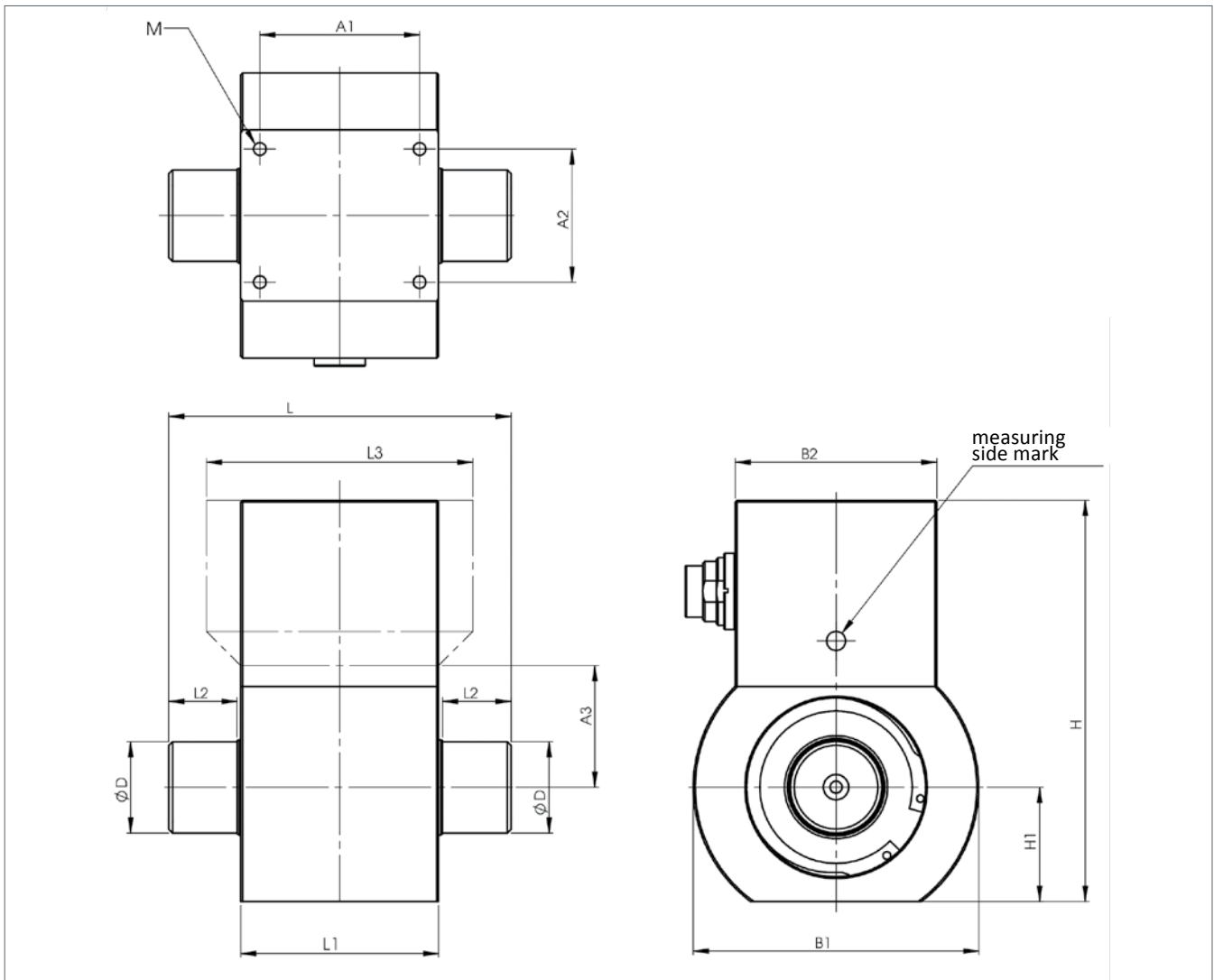

## Sizes DRBK-A

Sizes	0	I	II	III
Torque Ranges: ( $\pm 0$ - ... Nm)	0,5   1   2	5   10   20	50   100   200	500   1000
Dimensions:				
L (mm)	66	80	90	120
$\phi B1$ (mm)	45	70	75	105
B2 (mm)	54	53	53	76
H (mm)	90	100	106	122
H1 $\pm 0,05$ (mm)	18	28	30	40
$\phi D$ g6 (mm)	6	15	24	40
L1 (mm)	42	48	52	65
L2 (mm)	10	15	18	26
L3 (mm)	51	48	52	65
A1 (mm)	33	39	42	50
A2 (mm)	20	31	35	55
A3 (mm)	22	-	-	-
M	M3 x 5 deep	M4 x 6 deep	M4 x 6 deep	M5 x 10 deep
General tolerances DIN 2768 - m				
Weight approx.: (g)	310	610	910	2530
Speed max.: ( $\text{min}^{-1}$ )	20000	18000	16000	9000

## Technical Specifications DRBK + DRBK-A

Sizes	Torsion ShaftType	Measuring range (± 0 - ... Nm)	spring constant C (Nm/rad)	Mass Moment J (g•cm <sup>2</sup> )			Permitted Axial load (N) *	Permitted Radial load (N) *
				Total	Drive side	Measuring side		
	DRBK-0.5	0,5	144	15	14,5	0,5	190	30
	DRBK-1	1	144	15	14,5	0,5	190	30
	DRBK-2	2	287	15	14,5	0,5	190	60
I	DRBK-5	5	1100	130	115	15	930	25
	DRBK-10	10	2700	130	115	15	930	45
	DRBK-20	20	5400	130	115	15	930	90
II	DRBK-50	50	20 x 10 <sup>3</sup>	400	300	100	1580	210
	DRBK-100	100	36 x 10 <sup>3</sup>	400	300	100	1580	420
	DRBK-200	200	52 x 10 <sup>3</sup>	400	300	100	1580	845
III	DRBK-500	500	290 x 10 <sup>3</sup>	3300	1900	1400	3920	1420
	DRBK-1000	1000	420 x 10 <sup>3</sup>	3500	2000	1500	3920	2875

\*The values for axial and radial load refer to the non-fixed housing

## Features

- Supply is protected against overvoltage max 60 V DC (permanent)
- The outputs are short-circuit proof
- Contact for „Tranducer ready“ 100 mA 30 V DC

## Available Accessories

Cables, Analyzers, Couplings

## Compatible Couplings

for Size 0 MK2/20/40/6/x

for Size I BKE/20/15/x

for Size II BKE/200/24/x

for Size III BKE/1000/40/x

## Ordering Example

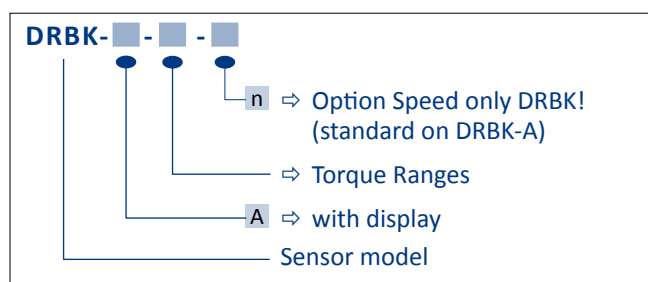

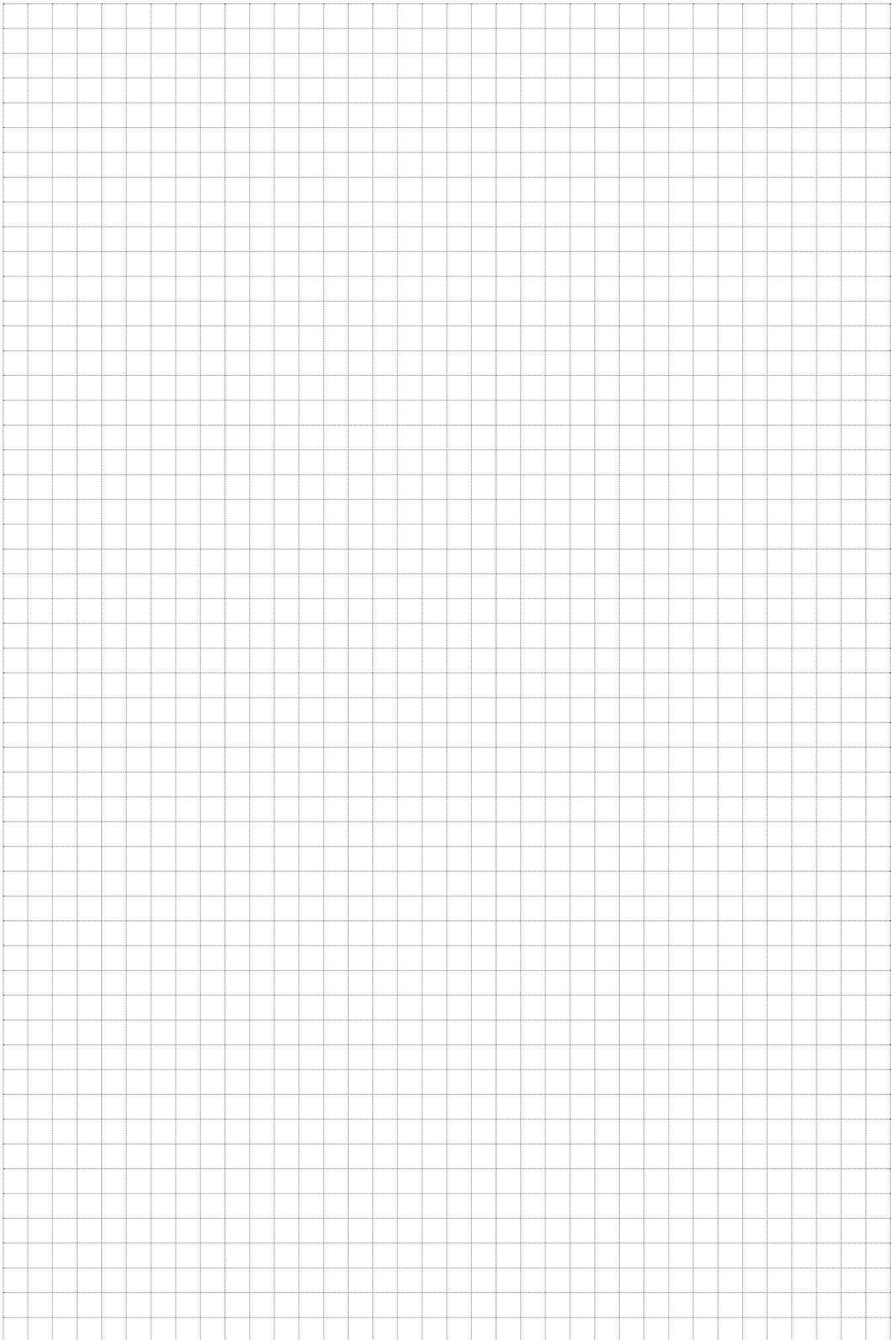

## Datasheet

Torque Transducer, waterproof

# DRWPL

15 torque ranges from  $\pm 0 - 0,1$  up to  $\pm 0 - 1500$  Nm  
waterproof IP 67  
with angle and speed measurement

### Features DRWPL

- waterproof IP 67
- contactless
- integral torque amplifier
- single supply voltage
- wide range of applications
- small form
- low moment of inertia
- speed measurement (option)
- angle measurement (option)

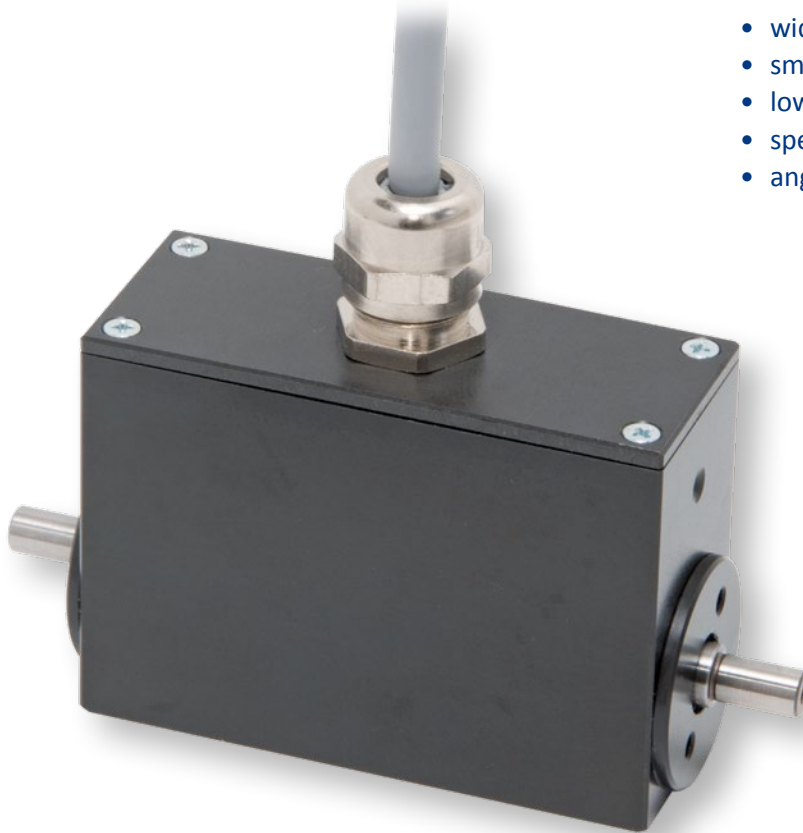

DRWPL series torque transducers are fitted with a number of gaskets in compliance with international protection IP 67.

The devices are also available with optional speed or angle detection for a host of applications. The integrated signal amplifier is powered with 12 V DC and outputs an electrically isolated analog signal of 0 to  $\pm 10$  V.

## Technical Specifications DRWPL

Supply voltage:	12 V DC $\pm$ 10 %
Power consumption:	approx. 200 mA
Rise time 10-90 %:	2 ms
Limit frequency –3 dB:	200 Hz (optional 1 kHz)
Voltage output:	0 to $\pm$ 10 V
Internal resistance:	100 $\Omega$
Ripple:	< 100 mVss
Nonlinearity/max. measurement error (of full scale):	0,1 %
Hysteresis:	0,1 %
Deviation at zero point:	$\leq \pm$ 100 mV
Max. measurement error:	0,1 % (FS / of full scale)
Operating temperature:	0 - 60 °C
Compensated temperature range:	5 - 45 °C
Temperature error	
Zero point:	0,02 % / K
Sensitivity:	0,01 % / K
Mechanical overload:	100 %
Internal protection:	IP67
Cable length:	2,5 m (standard)
Connection:	flying leads
Factory calibration right-/ left load in 25% steps. Special calibration on request.	

### EMV Immunity for interference (DIN EN 50082-2) \*1

Enclosure	Severity
HF line interference	
150 kHz - 80 MHz (AM)	10 V
ESD (Electrostatic discharge)	Air 8 kV / Contact 4 kV
Enclosure	
Electromagnetic field	
80 Mhz - 1000 MHz (AM)	10 V/m
150 kHz - 80 MHz (AM)	20 V/m
Leads - Connection Cable	
Burst (fast transients)	2 kV

\*1 Severity / criterion: industrial environment; Cable length  $\leq$  30 m. Application not outside buildings.

### Interference Emission (EN 55011)

Disturbance Voltage (electromagnetic disturbances)	Class B (150 kHz - 30 MHz)
Radiated Emission (electromagnetic disruption axis)	Class B (30 MHz - 1000 MHz)

### Speed Option (n)

max. rev.:	10.000 min <sup>-1</sup> *2
Output:	open-collector
Internal pull up:	10 k $\Omega$ (5 V level)
External pull up:	24 V max. / 20 mA
Pulses / rev.:	60

\*2 with suitable external wiring 20.000 min<sup>-1</sup>  
(or speed max. )

### Angle Option (w)

max. rev.:	3000 min <sup>-1</sup> *3
Output:	open-collector
Internal pull up:	10 k $\Omega$ (5 V level)
External pull up:	24 V max.
Pulses / rev.:	360
Resolution:	1°
Phase shift	Channel A 90° at right spin of propulsion side.

\*3 with suitable external wiring 15.000 min<sup>-1</sup>  
(or speed max. )



## Mechanical Dimensions DRWPL

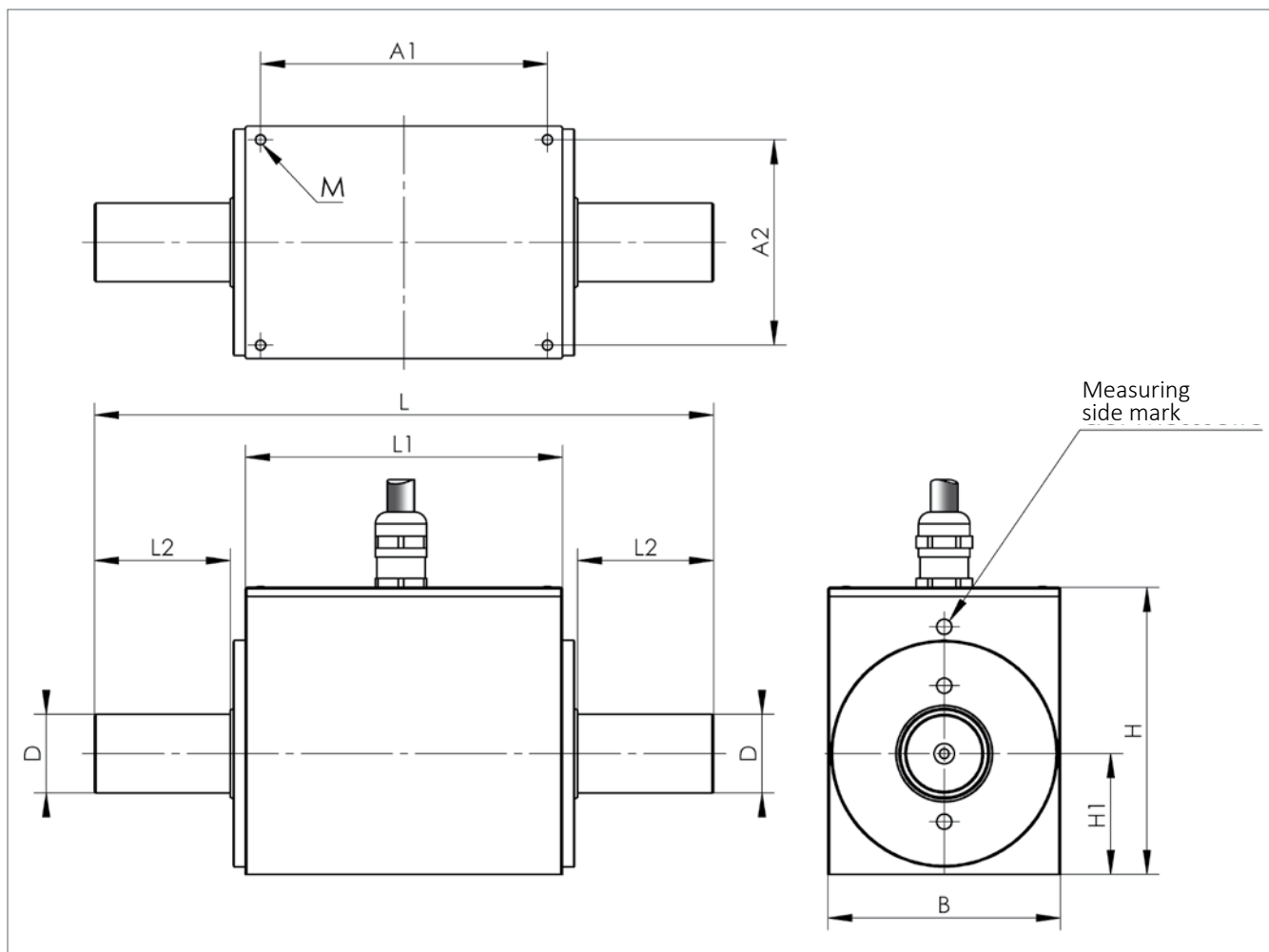

	<b>DRWPL-I</b>	<b>DRWPL-II</b>	<b>DRWPL-III</b>	<b>DRWPL-IV</b>
Torque range ( $\pm 0 - \dots$ Nm)	0,1   0,2   0,5   1   2	5   10   20   50	50   100   200   300	500   1000   1500
L (mm)	103	160	205	310
L1 (mm)	74	92	105	126
L2 (mm)	11	30	45	85
B (mm)	30	50	77	120
H (mm)	53	68	95	112
H1 (mm)	15	25	40	52
D g6 ( $\varnothing$ mm)	6	15	26	45
A1 (mm)	68	82	95	105
A2 (mm)	24	40	68	105
M	M3 x 5 deep	M4 x 8 deep	M4 x 8 deep	M6 x 10 deep
Weight approx. (g)	280	920	4925	8000
Speed max. (1/min)	20.000	10.000	5000	1900

General tolerances DIN 2768-m

## Technical Specifications DRWPL

Size	Torque range (±0 - ...Nm)	Spring constant C (Nm/rad)	Mass moment of inertia J (g•cm <sup>2</sup> )			Rated axial load (N) *	Rated radial load (N) *
			Total	Drive side	Measuring side		
I	0,1	33	7,7	6,8	0,9	140	1,5
	0,2	33	7,7	6,8	0,9	140	1,5
	0,5	86	7,9	6,9	0,8	160	2
	1	86	7,9	6,9	0,8	210	3,5
	2	173	7,9	7,0	1,0	210	6,5
II	5	936	111	77	34	930	10
	10	2017	111	78	33	930	20
	20	3626	112	78	34	930	50
	50	5808	116	80	36	930	110
III	50	15.471	984	560	424	1820	60
	100	25.696	993	564	429	1820	130
	200	41.762	1020	578	442	1820	250
	300	48.872	1047	591	456	1820	380
IV	500	205.695	11.778	6455	5323	4160	522
	1000	290.236	12.011	6572	5439	4160	1019
	1500	327.886	12.277	6705	5572	4160	1502

\*The values for axial and radial load apply to the non-fixed housing

## Ordering code system

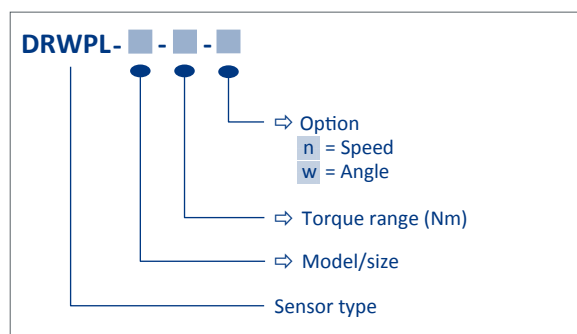

## Available Accessories

Supply and display unit ValueMaster<sub>base</sub>  
Couplings

## Datasheet

### Torque Transducer

# DRFN

20 torque ranges from  $\pm 0 - 1$  up to  $\pm 0 - 5000$  Nm  
square drive  
and either with or without angle function



### Features DRFN

- No service needed because of contactless data acquisition
- High noise immunity due to amplified active signal
- High accuracy due to frequency modulation and strain gage technology
- Single power supply
- Optional angle detection
- integrated sensor-detection chip for use with GMV2 analyzer

**suitable for**  
automotive industry  
test benches  
assembly applications  
pulsed tools

The transducer is suited for the most varied measurement duties on threaded fasteners, to check and adjust assembly tools, like screwdrivers and spanners, and to sense loosening torques, etc. It can also be deployed in blocked mode to test torque wrenches. The device is powered wirelessly and the electrical output

is wireless, as well. Hence, there is practically no wear on the device.

This sensor is suited for cyclical as well as continuous testing of tools. As the sensor is designed to be torsionally rigid any errors due to it are minimized.

### Models / Fittings

Static retainer / clamping device for torque wrenches

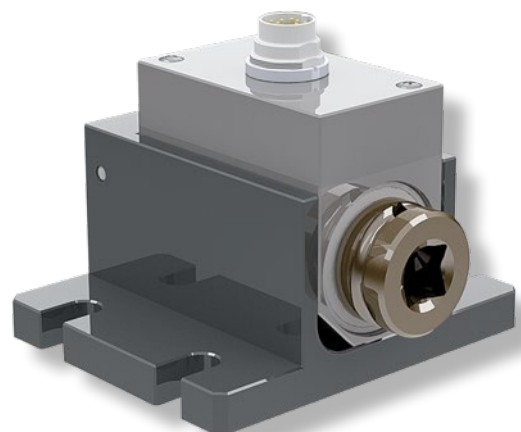

## Electrical Specifications DRFN

Supply voltage:	12 V DC $\pm$ 10 %
Current consumption:	< 200 mA
Rise time 10-90 %:	1 ms (1 kHz)
Voltage output:	0 to $\pm$ 5 V
Internal resistance:	100 $\Omega$
Ripple:	< 100 mV <sub>ss</sub>
Nonlinearity:	< 0,15 %
Hysteresis:	< 0,1 %
Deviation at zero point:	$\leq \pm$ 100 mV
Operating temperature:	0 - 60 °C
Compensated temperature range:	5 - 45 °C
Temperature error	
Zero point:	0,02 % / K
Sensitivity	0,01 % / K
Mechanical overload:	see table
Internal protection:	IP40
Connection:	12pin-connector
Factory certificate for clockwise torque in 25% steps is also supplied. (Other calibrations available on request!)	

<b>Angle Option (w)</b>	
Max. rev.:	3000 min <sup>-1</sup>
Output:	open-collector
Internal pull up:	10 k $\Omega$ (5 V level)
External pull up:	24 V max.
I <sub>max</sub> :	20 mA
Pulses / rev.:	360
Resolution:	1°

### Detection of direction of rotation:

2 pulses 90° phase shift

Channel A leading for clockwise rotation of drive end

## Ordering Example

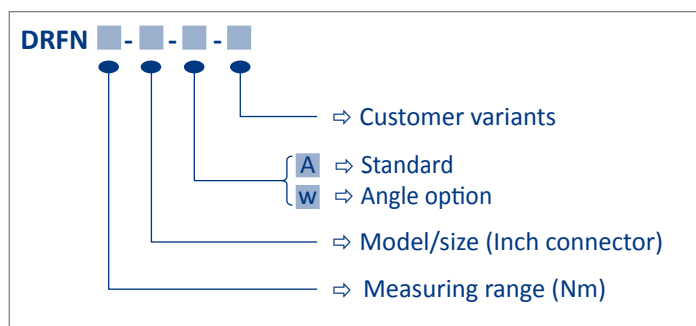

## Accessories

Analyzer: ValueMaster<sub>base</sub>  
GMV2

Cables  
Static holders (SH)

## Mechanical Dimensions DRFN

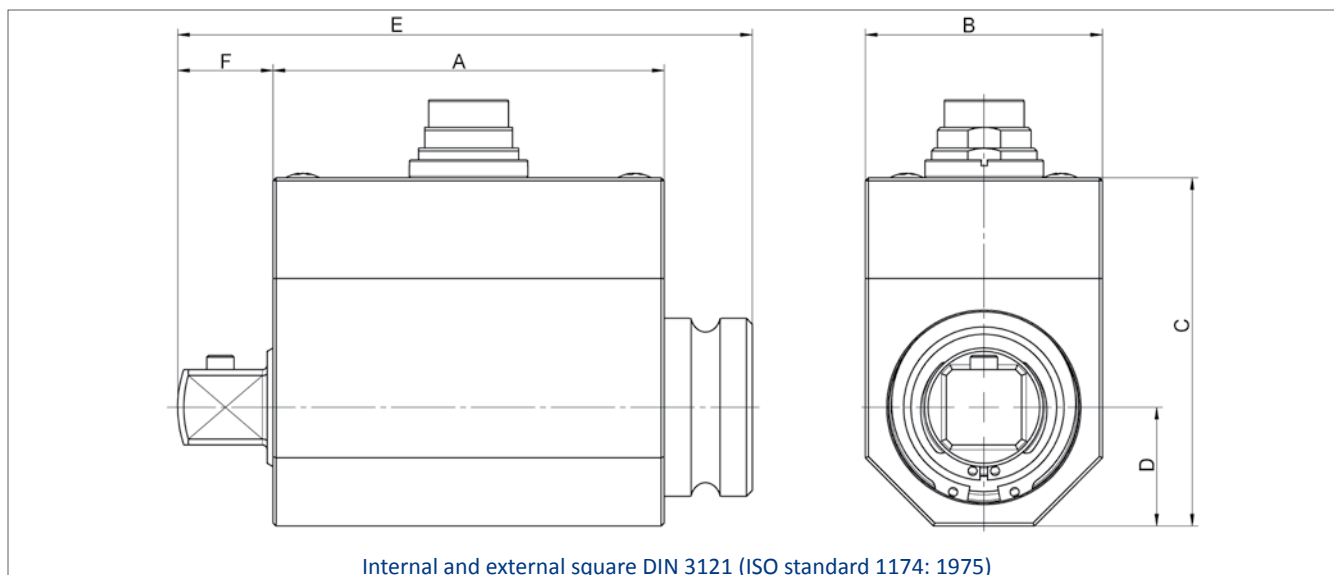

## Mechanical values and load limits DRFN

Size (inch)	$n_{max}$ (l/min)	Torque range ( $\pm 0 - \dots$ Nm)	Overload (%)	A (mm)	B (mm)	C (mm)	D (mm)	E (mm)	F (mm)	Weight approx (g)
1/4"	12.000	1   2   5   10   12   15 20	100 70 30	62	32	56	16	77	8	300
3/8"	12.000	20   30   50   63	100 80	62	34	52	16,5	82	12	350
1/2"	12.000	100 160 200	100 60 30	66	40	57	20	95	16	480
3/4"	12.000	200   300   500	100 50	66	46	65	23	110	24	800
1"	12.000	1000 2000	50 30	66	52	71	25,5	127	31	1250
1 1/2"	7000	2000   3000     4000   5000	100 50	86	92	108	46	178	44	4800
with rotation angle measurement	1/4"-w	1   2   5   10 12   15   20	100 80 50 30	66	32	51	16	82	9	250
	3/8"-w	20   30   50   63	100 80	66	40	59	20	90	12	400
	1/2"-w	100 160 200	100 60 30	66	40	59	20	97	16	480
	3/4"-w	200   300   500	100 50	71	55	74	27,5	117	24	1050
	1"-w	1000	50	72	56	73	28	132	30,5	1250
	1 1/2"-w	7.000	2000   3000     4000   5000	100 50	86	92	108	46	178	44

General tolerances DIN 2768-m

## Mechanical Dimensions DRFN static holder (SH)

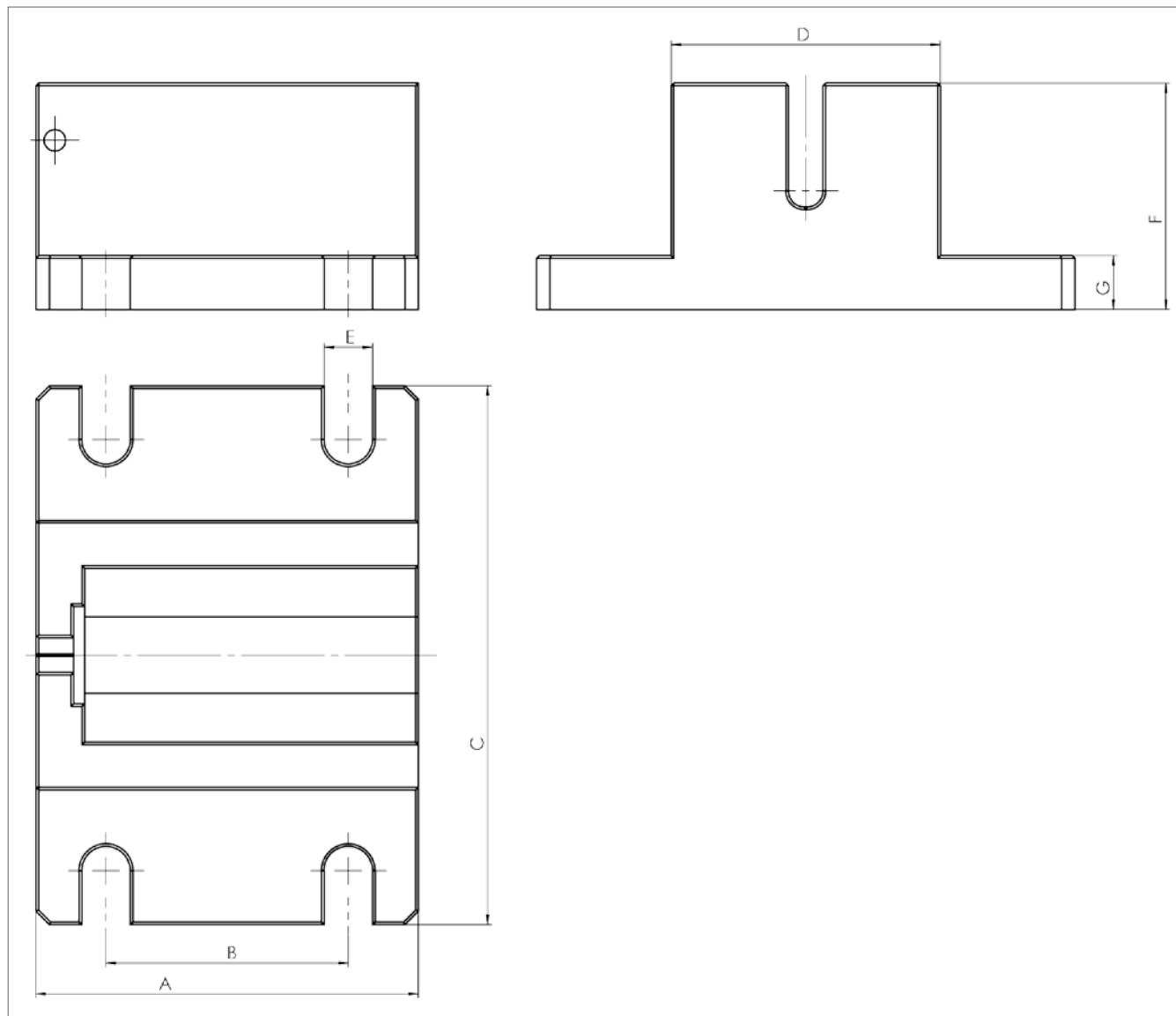

Model	A	B	C	D	E	F	G
SH-DRFN ¼"	71	45	100	50	9	42	10
SH-DRFN ⅜"	74	45	100	50	9	45	10
SH-DRFN ½"	82	45	100	50	9	50	10
SH-DRFN ¼"-w	76	45	100	50	9	43	10
SH-DRFN ⅜"-w	78	45	100	50	9	45	10
SH-DRFN ½"-w	82	45	100	50	9	50	10

The static retainer (SH) is available on customer request for models DRFN ¼", 1", ½" and DRFN ¼"-w, 1"-w, ½"-w.

## Ordering code System

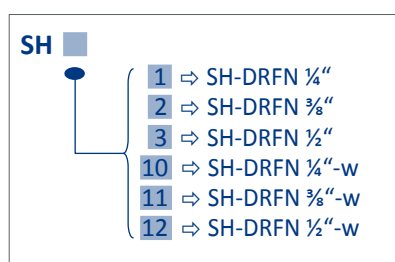

## Datasheet

### Torque Transducer

# DRFS + DRFS-I-W

DRFS: 7 torque ranges from  $\pm 0 - 1$  up to  $\pm 0 - 20$  Nm

DRFS-I-w: 6 torque ranges from  $\pm 0 - 0,5$  up to  $\pm 0 - 20$  Nm

### Hexagonal drive

suitable for motor vehicle,  
test bench and assembly technology

suitable for pulse tool

optional angle function

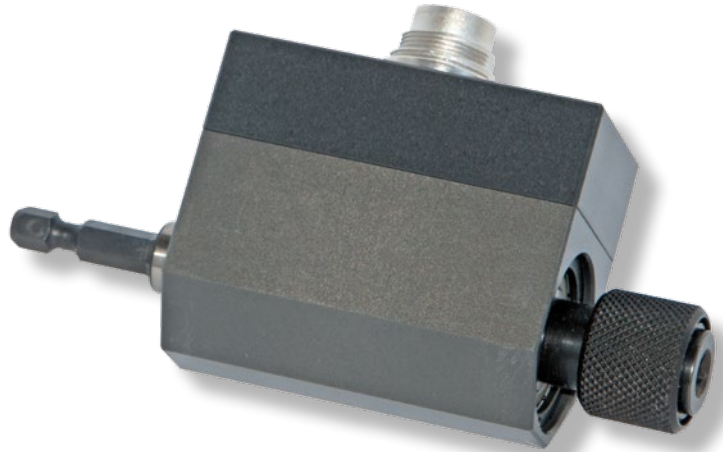

### Features DRFS

- No service needed because of contactless data acquisition
- High accuracy due to frequency modulation and strain gage technology
- Single power supply
- High noise immunity due to amplified active signal
- integrated sensor-detection chip for use with GMV2 analyzer

## Measuring Range

DRFS ( $\pm 0 - \dots$ Nm)	Overload (%)
1   2   5   10   12	100
15	70
20	30

DRFS-I-w ( $\pm 0 - \dots$ Nm, with angle function)	Overload (%)
0,5   1   2   5	100
10	80
20	10

## Electrical Specifications

Supply voltage:	12 V DC $\pm$ 10 %
Current consumption:	< 200 mA
Rise time 10-90 %:	1 ms (1 kHz)
Voltage output:	0 to $\pm$ 5 V
Internal resistance:	100 $\Omega$
Ripple:	< 100 mVss
Nonlinearity:	< 0,15 %
Hysteresis:	< 0,1 %
Deviation at zero point:	$\leq \pm$ 100 mV
Operating temperature:	0 - 60 °C
Compensated temperature range:	5 - 45 °C
Temperature error	
Zero point:	0,02 / K
Sensitivity:	0,01 / K
max rev. (DRFS):	10.000 min <sup>-1</sup>
Internal protection:	IP40
Connection:	12pin-connector
Calibration: Works certificate with 25% steps cw. Other calibrations on request.	

Angle / DRFS-I-w	
max rev.:	3000 min <sup>-1</sup>
Output:	open-collector
Internal pull up:	10 k $\Omega$ (5 V Pegel)
External pull up:	24 V max.
I <sub>max</sub> :	20 mA
Pulses / rev.:	360
Resolution:	1°
Detection of direction of rotation:	2 pulses 90° phase shift Channel A leading for clockwise rotation of drive end

## Ordering Code System

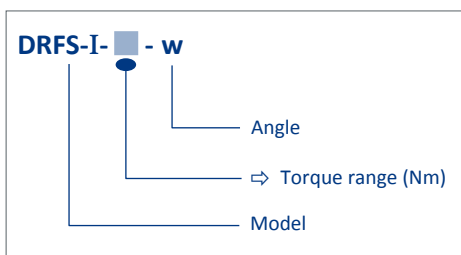
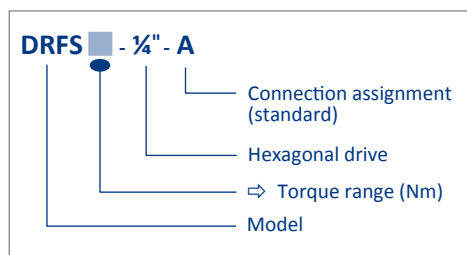



## Mechanical dimensions

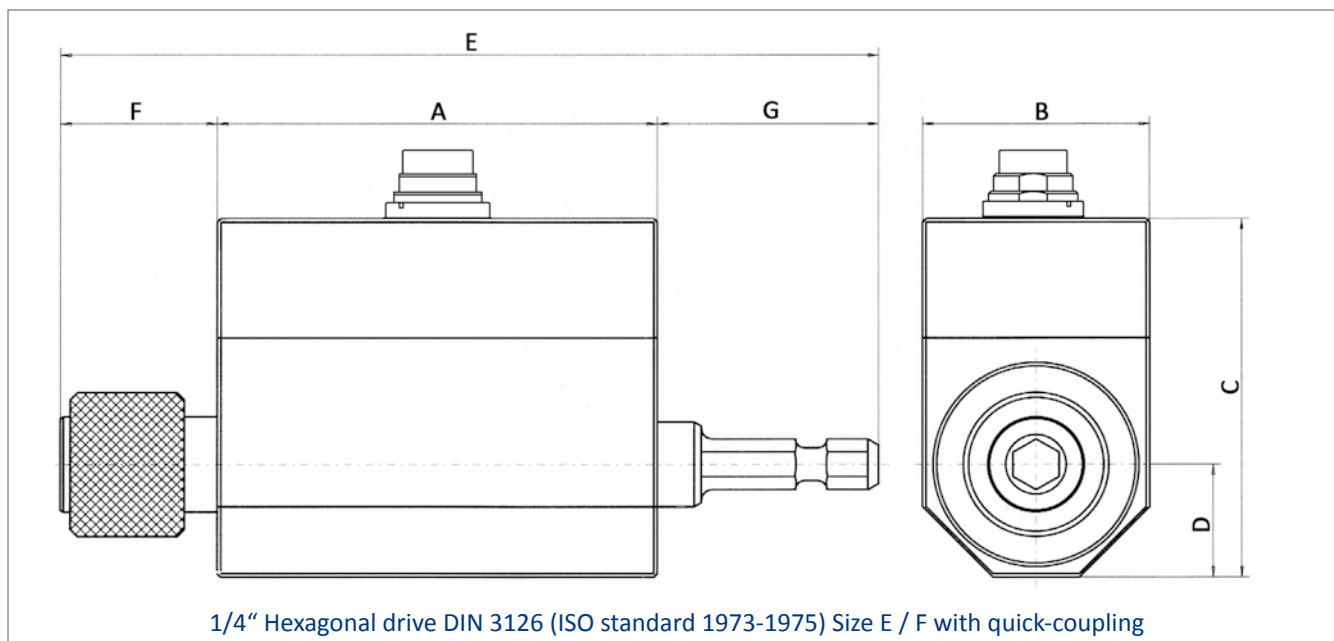

## Mechanical values

Model	A (mm)	B (mm)	C (mm)	D (mm)	E (mm)	F (mm)	G (mm)	Weight approx (g)
<b>DRFS</b>	62	32	51	16	115	22	31	300
<b>with angle function</b>								
<b>DRFS-I-w</b>	66	32	51	16	114	17	30	280

General tolerances DIN 2768-m

## Available Accessories

Supply and display unit: ValueMaster<sub>base</sub>  
GMV2  
ValueView

Cables

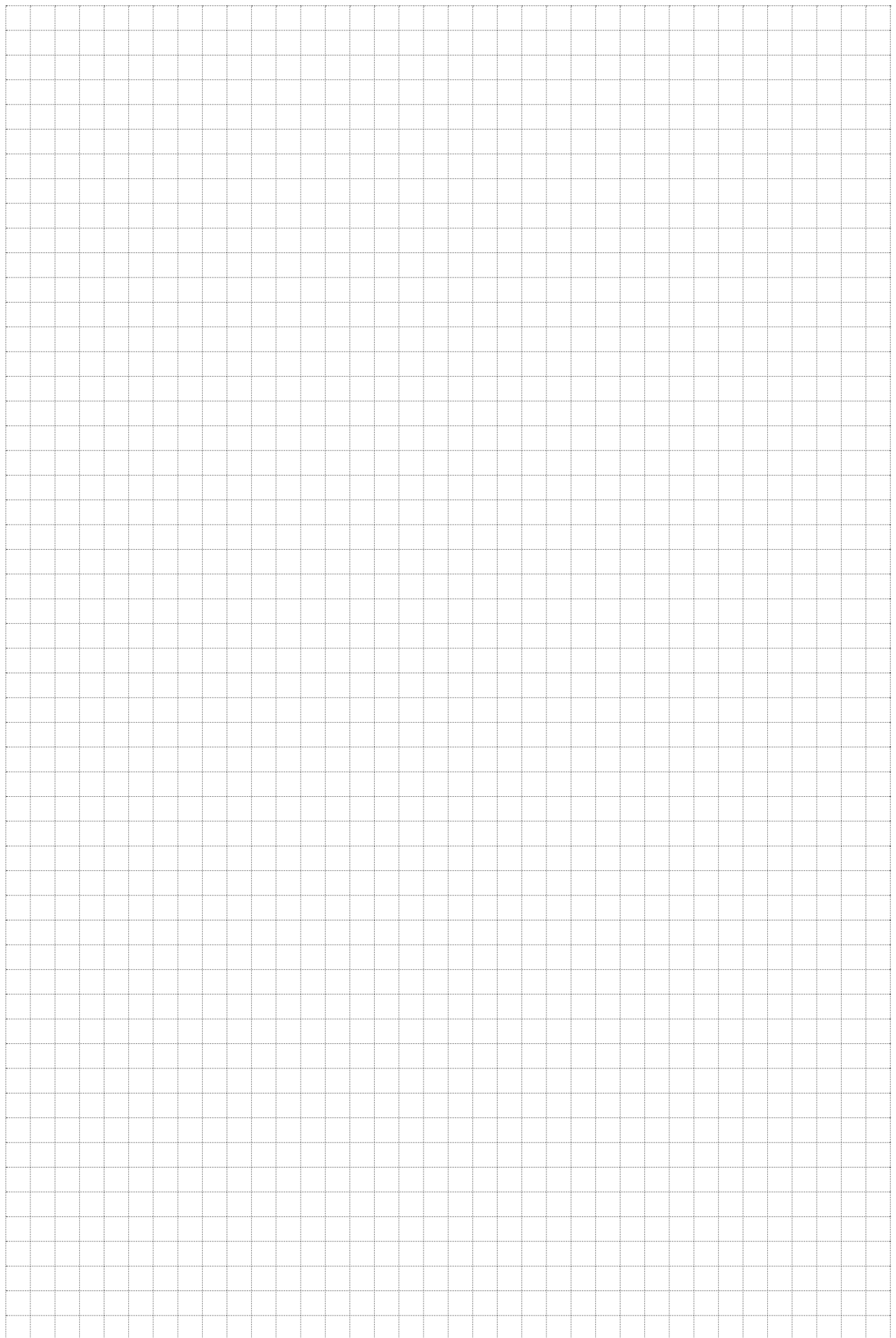

## Datasheet

### Torque Transducer

# DRFS ¼"-W-S

7 torque ranges from  $\pm 0 - 1$  up to  $\pm 0 - 20$  Nm

with hex drive and identification  
of angle rotation

for the documentation  
in the screwing technique  
according to DIN EN ISO 9000 ff



## Features

- universal attachment to standard electric screwdrivers
- rigid connection between transducer and screwdriver
- lockable in any position, thus easy handling
- maintenance-free due to non-contact measured value transmission
- high accuracy through frequency modulation and DMS principle
- high interference immunity due to amplified active signal
- integrated chip for sensor detection in conjunction with evaluation unit GMV2 and ValueMasterbase

## Torque ranges

DRFS ¼" -w-S (±0 - ... Nm)	Mechanical overload
1   2   5   10   12	100 %
15	70 %
20	30 %

## Electrical Specifications DRFS

Supply voltage:	12 V DC ± 10 %
Power consumption:	< 200 mA
Rise time 10-90 %:	1 ms (1 kHz)
Voltage output:	0 to ± 5 V
Internal resistance:	100 Ω
Ripple:	< 100 mV <sub>ss</sub>
Nonlinearity:	< 0,15 %
Hysteresis:	< 0,1 %
Deviation at zero point:	≤ ± 100 mV
Operating temperature:	0 - 60 °C
Compensated temperature range:	5 - 45 °C
Temperature error	
Zero point:	0,02 % / K
Sensitivity:	0,01 % / K
Max rev.:	8000 min <sup>-1</sup>
Weight approx.:	250 g
Protection:	IP 40
Connection:	2,5m cable with 12pin- connector
Calibration: Factory certificate with 25% steps cw. Other calibrations upon request.	

Angle option (w)	
Max. rev.:	3000 min <sup>-1</sup>
Output:	open-collector
Internal pull up:	10 kΩ (5 V level)
External pull up:	24 V max.
I <sub>max</sub> :	20 mA
Pulses / rev.:	360
Resolution:	1°
Detection of direction of rotation:	2 Imp. 90° Phase shift Channel A clockwise of the drive side leading

## Ordering code

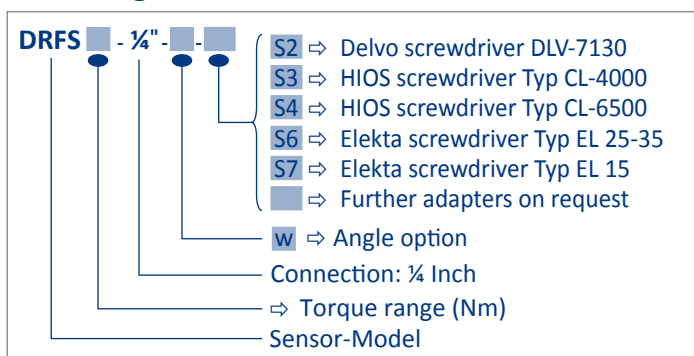

## Mechanical dimensions DRFS

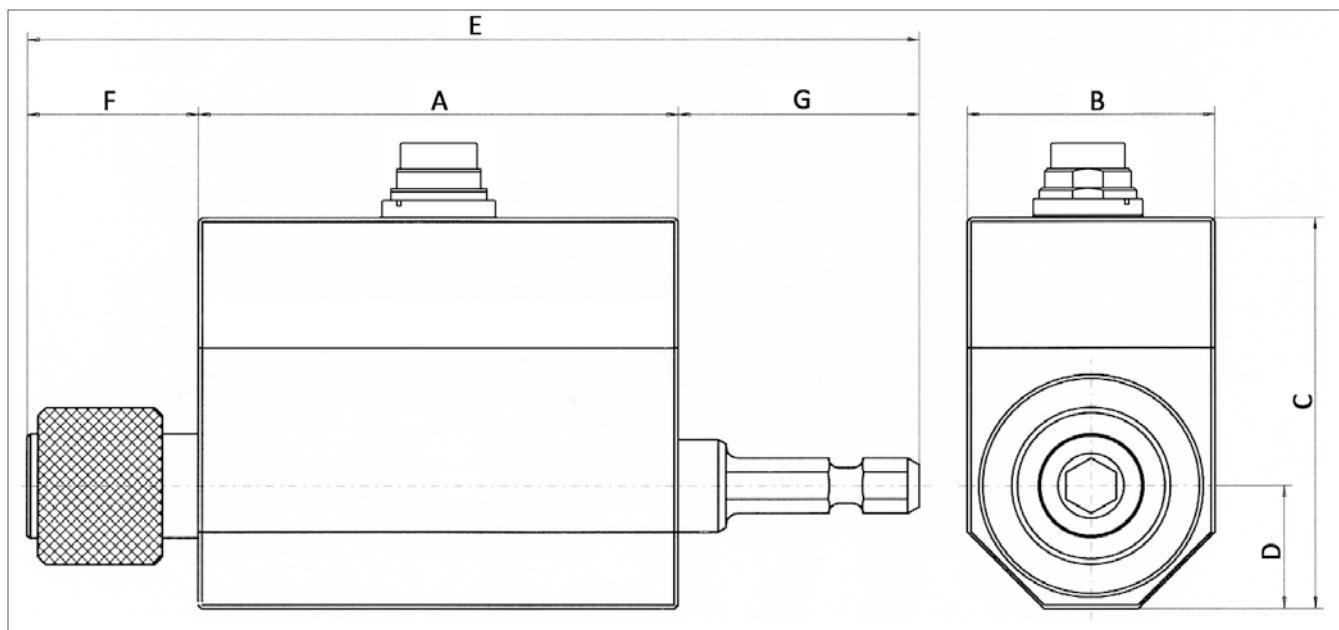

1/4" Hexagonal drive DIN 3126 (ISO standard 1973-1975) Size E / F with quick-coupling,

## Mechanical values

Model	A (mm)	B (mm)	C (mm)	D (mm)	E (mm)	F (mm)	G (mm)	H (mm)	I (mm)	Weight approx. (g)
DRFS 1/4" -w-S	66	32	51	16	105	17	30	75	42	280

General tolerances DIN 2768-m

## Available Accessories

Supply and display unit: ValueMaster<sub>base</sub>  
GMV2  
ValueView

Cables

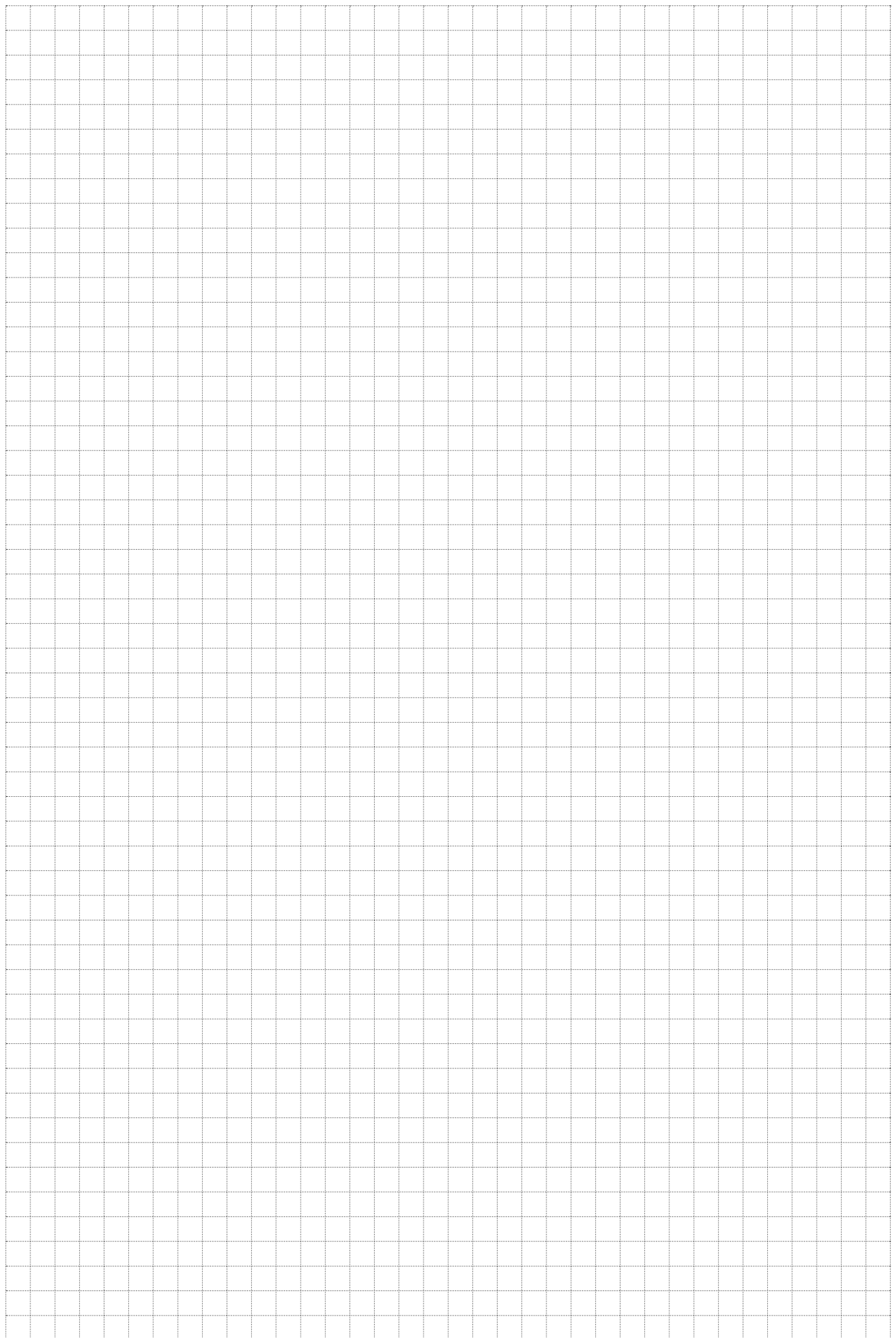

## Datasheet

### Torque Transducer

# DRFSK

#### Very short!

6 torque ranges from  $\pm 0 - 2$  up to  $\pm 0 - 20$  Nm

#### Hex drive

Suitable for motor vehicle,  
test bench and assembly technology

Suitable for impulse tools

Optional angle measurement



## Features

- Short form, especially suitable for automatic screwing machines
- Quick-release coupling
- Measurement, adjustment and examination without removing the screwing tool
- Frequency modulation and strain gauge principle cause high accuracy
- Suitable for clockwise and counter-clockwise measurement
- High interference rejection because of amplified active signal
- No service needed because of contact-less data acquisition
- High accuracy because frequency modulation and DMS principle
- Ordinary power supply
- Integrated chip for sensor detection  
in connection with evaluation unit GMV2 or ValueMasterbase

## Electrical Specifications DRFSK

Torque ranges ( $\pm 0 - \dots$ Nm):	2   5   10   12   15   20
Power consumption:	12 V DC $\pm 10$ %
Current consumption:	approx. 200 mA (DRFSK-w approx. 225 mA)
Rise time 10 - 90 %:	1 ms (1 kHz)
Voltage output:	0 to $\pm 5$ V
Internal resistance:	100 $\Omega$
Ripple:	< 100 mVss
Nonlinearity:	< 0,15 %
Hysteresis:	< 0,1 %
Max. measurement error:	< 0,15 %
Deviation at zero point:	$\leq \pm 100$ mV
Operating temperature:	0 - 60 °C
Compensated temperature range:	5 - 45 °C
Temperature error	
Zero point:	0,02 % / K
Sensitivity:	0,01 % / K
Output signal:	$\pm 5$ V
Speed max:	10.000 min <sup>-1</sup>
Protection:	IP40
Weight approx.:	280 g
Connection:	12pin- connector
Calibration: Works certificate with 25% steps cw. Other calibrations upon request.	

Angle option (w)	
Max. rev.:	3000 min <sup>-1</sup>
Output:	open-collector
Internal pull up:	10 k $\Omega$ (5 V Pegel)
External pull up:	24 V max.
I <sub>max</sub> :	20 mA
Pulses / rev.:	360
Resolution:	1°

Detection of direction of rotation
2 Imp. 90° Phase shift
Channel A clockwise of the of the drive side leading

## Ordering code

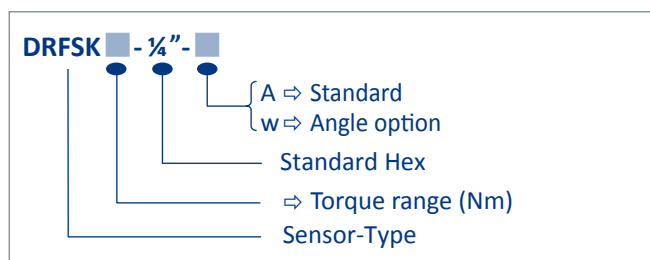

## Accessories

Analyzer: GMV2  
ValueMaster<sub>base</sub>

Cables



## Mechanical Dimensions DRFSK

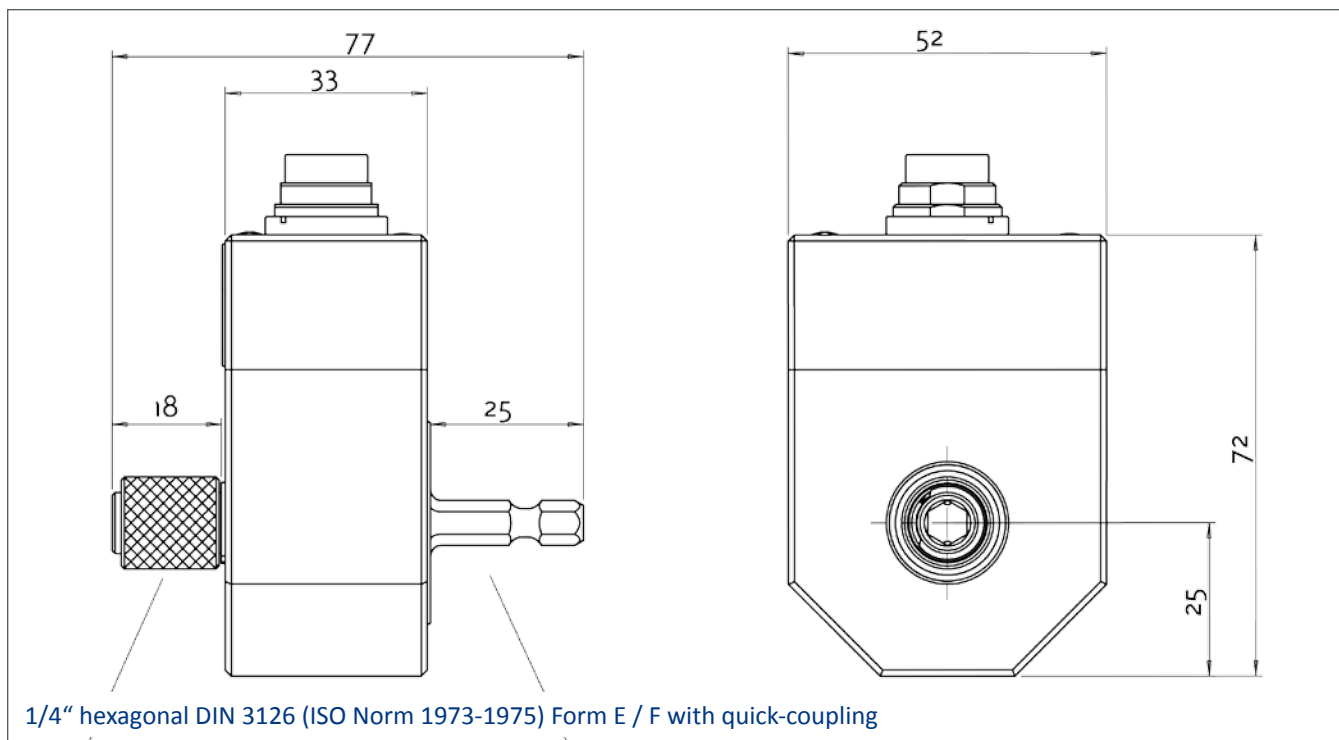

General tolerances DIN 2768-m

## Technical Specifications DRFSK

Torque range (±0 - ... Nm)	Spring constant C (Nm/rad)	Mass moment of inertia J (g•cm <sup>2</sup> )	Rated axial load (N)	Rated radial load (N)	Mechanical overload
2	370	60	21	21	100%
5	980	60	53	53	100%
10	1630	60	104	104	80%
12	1740	60	115	115	30%
15	1740	60	115	115	30%
20	1740	60	115	115	30%

## Technical Specifications DRFSK-w (with angle measurement)

Torque range (±0 - ... Nm)	Spring constant C (Nm/rad)	Mass moment of inertia J (g•cm <sup>2</sup> )	Rated axial load (N)	Rated radial load (N)	Mechanical overload
2	389	29	197	25	100%
5	1160	29	197	60	100%
10	2245	30	197	120	80%
12	2451	30	197	140	30%
15	2451	30	197	140	30%
20	2451	30	197	140	30%

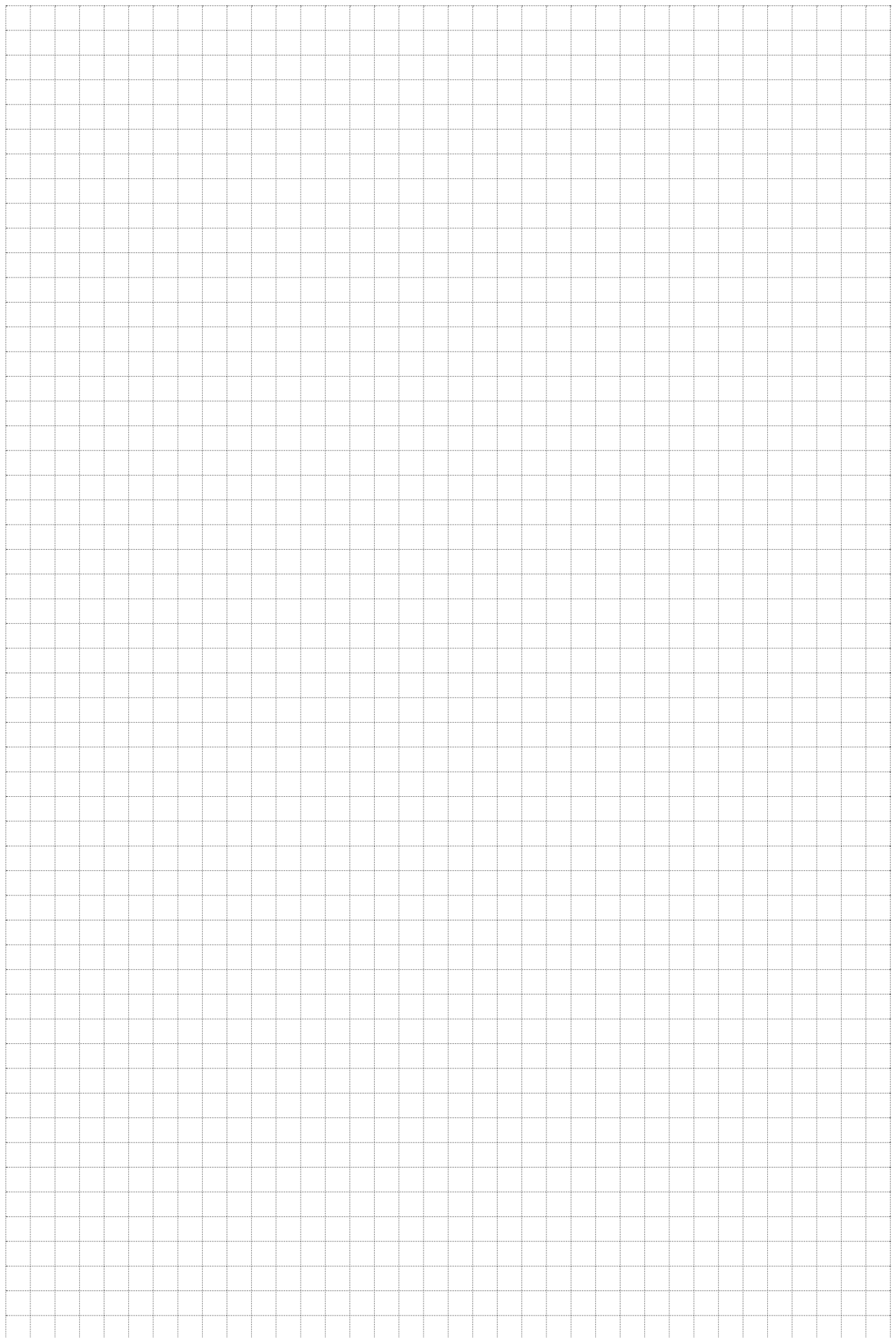

## Datasheet

### Torque Transducer

# DRFDN

# DRFDS

4 torque ranges from  $\pm 0 - 0,5$  up to  $\pm 0 - 5$  Nm

with digital output

option angle function



## Features

- No service needed because of contactless data acquisition
- High accuracy due to frequency modulation and strain gage technology
- reduced power consumption
- High noise immunity due to digital signal
- very compact design

**suitable for:**  
automotive industry  
test benches  
assembly applications  
pulsed tools

The transducer is suitable for use in the laboratory and for the industrial environment due to its compact dimensions. The non-contact transmission of supply voltage and measuring signal enables low-wear and

maintenance-free continuous operation. The integrated measuring amplifier delivers a digital output signal of  $8 \text{ kHz} \pm 2 \text{ kHz}$  with a supply voltage of 12V DC.

## Electrical Specifications DRFD

Torque ranges: ( $\pm 0$ -... Nm)	0,5   1   2   5
Supply voltage:	12 V DC $\pm$ 10 %
Current consumption:	< 150 mA
Frequency output:	8 kHz $\pm$ 2 kHz
Level:	8 V
Accuracy:	0,25 % of full scale
Nonlinearity:	< 0,15 %
Hysteresis:	< 0,1 %
Operating temperature:	0 - 60 °C
Compensated temperature range:	5 - 45 °C
Temperature error	
Zero point:	0,02 % / K
Sensitivity:	0,01 % / K
Mechanical overload:	100 %
Internal protection:	IP40
max rev.:	10.000 min <sup>-1</sup>
Weight:	approx. 180 g
Connection:	8pin-connector
Calibration: Factory certificate with 25% steps cw. Other calibrations on request.	

Angle option (w)	
Max rev.:	3000 min <sup>-1</sup>
Output:	open-collector
Internal pull up:	10 k $\Omega$ (5 V level)
External pull up:	24 V max
I <sub>max</sub> :	20 mA
Pulses / rev.:	360
Resolution:	1°

Detection of direction of rotation:
2 pulses 90° phase shift
Channel A leading for clockwise rotation of drive end

## Ordering Code

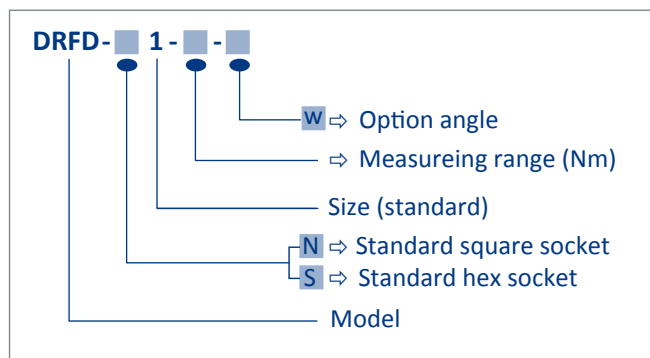

## Accessories

external D / A converter for analog signal,  
supply and evaluation device GMV2,  
Cable 2m

## Mechanical Dimensions DRFD

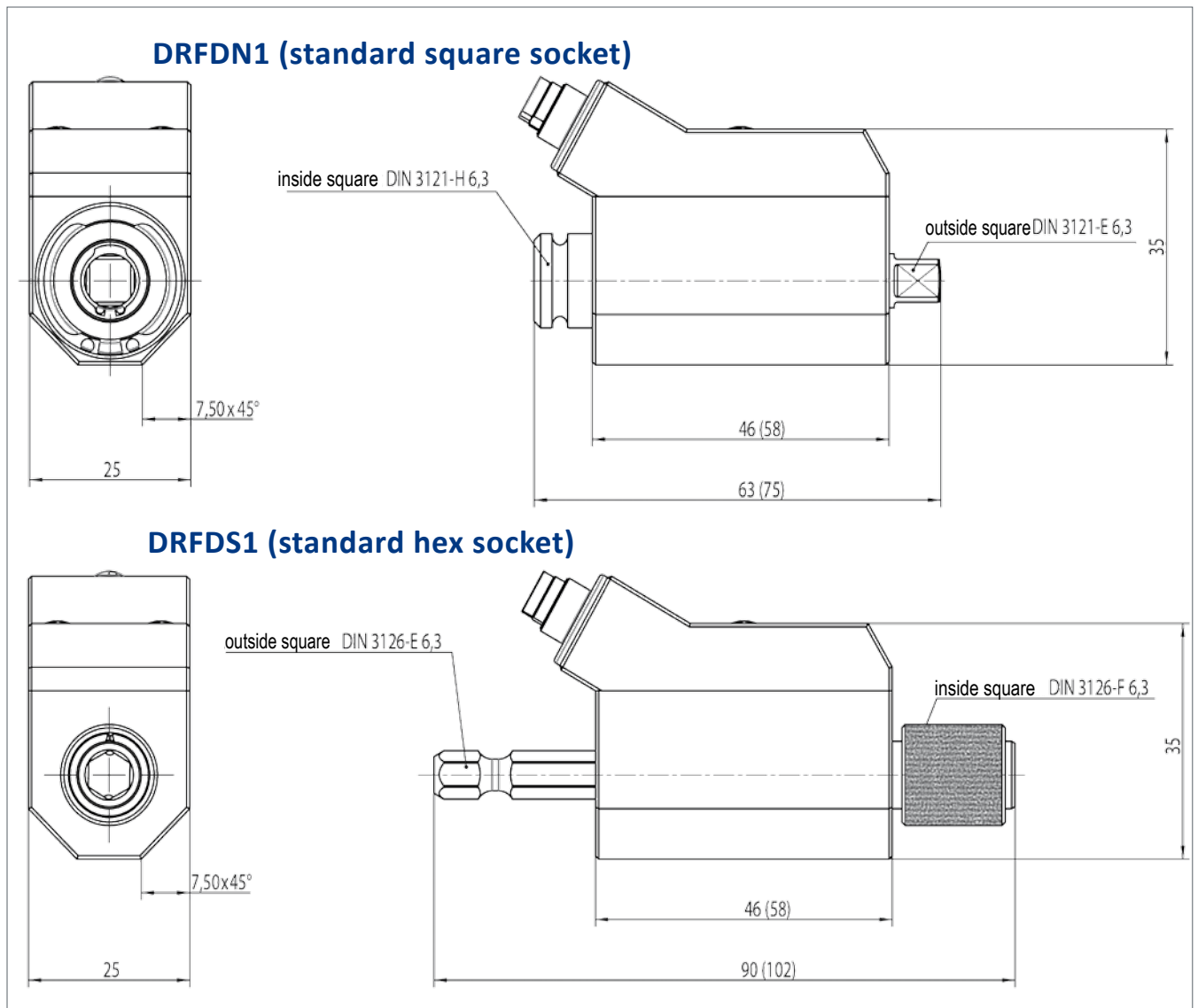

In brackets dimensions with option rotation angle. / General tolerances DIN 2768-m.

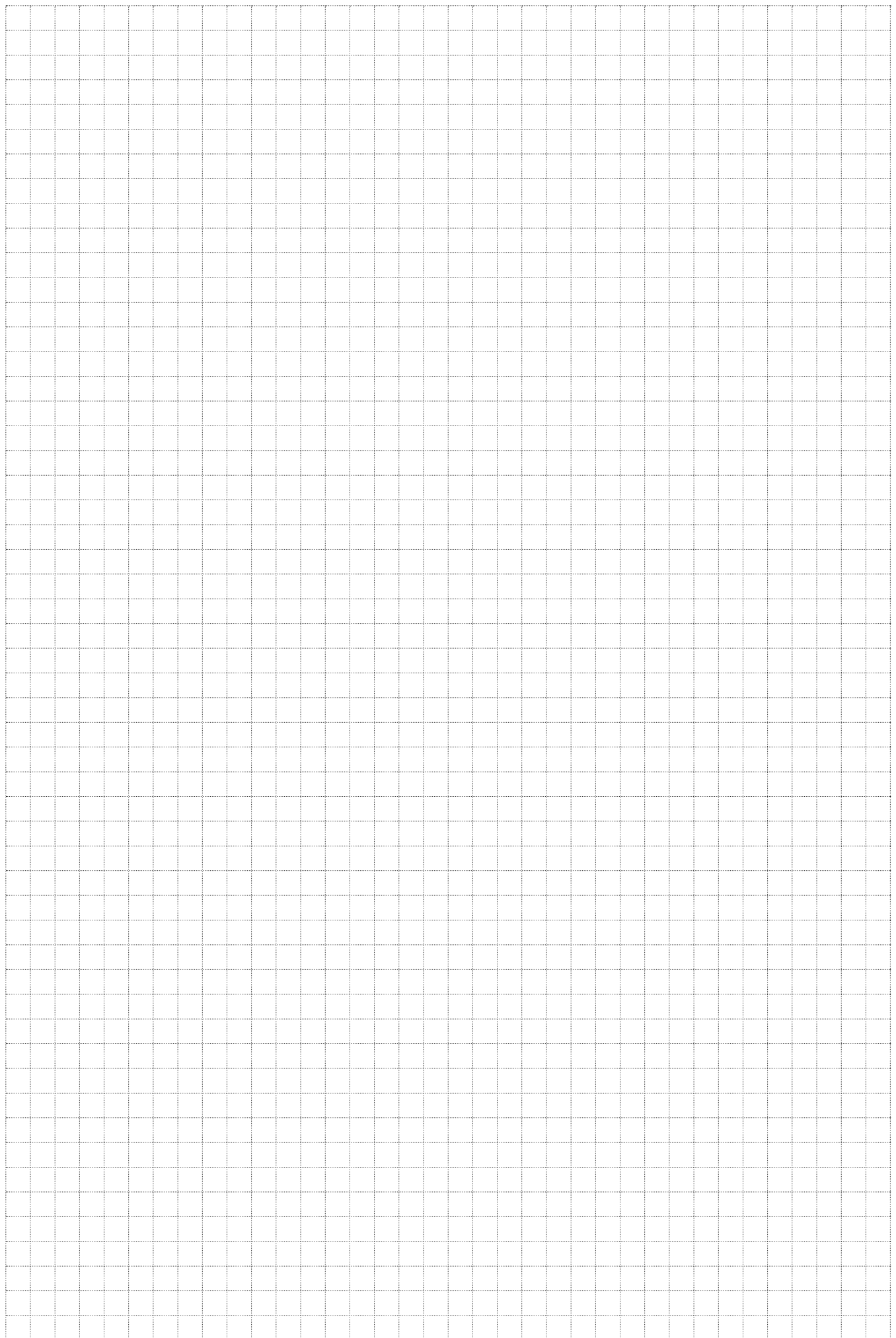

## Datasheet

### Reaction Torque Transducer

# DRT

16 torque ranges from  $\pm 0 - 2$  up to  $\pm 0 - 6000$  Nm  
for static applications  
active or passive-model

### Features

- suitable for impulse screwdrivers
- side load insensitive
- permanently mountable
- exchangeable adapters
- integrated chip for sensor detection
- in connection with evaluation unit GMV2
- for screwing simulator

### suitable for

- testing pulsed tools
- torque wrenches
- electric screwdrivers

This transducer was developed for static testing of pulsed tools, torque wrenches, electric screwdrivers, etc. In combination with the universal torque meter GMV2 a torque wrench can be tested without falsifying the result by excessively tightening the wrench. The transducer can be mounted in any position with the help of the flange bracket to suit the tool to be



Sensor mounted with bracket



tested. A variety of adapters are available for accepting the tool so that the tool can be tested with or without a socket. The device shaft is fitted with strain gages. It is not impacted by lateral loading because of the arrangement of the strain gages and an additional ball bearing.

## Electrical Specifications DRT

Model:	active	passive
Torque ranges: ( $\pm 0$ - ... Nm)		
DRT1	2   5   10   12   20	2   5   10   12   20
DRT2	50   100   200   300	50   100   200   300
DRT3	500   1000   2000   3000	500   1000   2000   3000
DRT4	4000   5000   6000	4000   5000   6000
Supply voltage:	12 V DC $\pm$ 10 %	12 V max.
Power consumption:	approx. 30 mA	35 mA max.
Voltage output:	0 to $\pm$ 5 V	DRT1 + DRT2 1 mV/V DRT3 + DRT4 2 mV/V
Nonlinearity:	DRT1 +2 0,1 % DRT3 + 4 0,15 %	0,1 % 0,15 %
Hysteresis:	0,1 %	0,1 %
Deviation at zero point:	$\leq \pm$ 100 mV	$\leq \pm$ 0,01 mV/V
Internal resistance:	---	350 $\Omega$ nominal
Operating temperature:	0 - 60 °C	0 - 60 °C
Compensated temperature range:	5 - 45 °C	5 - 45 °C
Temperature error		
Zero point:	0,02 % / K	0,02 % / K
Sensitivity	0,01 % / K	0,01 % / K
Internal protection:	IP40	IP40
Connection:	12pin-connector	6pin-connector

Model	Weight approx. (kg) without mounting bracket	Weight approx. (kg) with mounting bracket
DRT1	0,7	1,8
DRT2	1,6	2,8
DRT3	5,6	17
DRT4	23	52

Model	Torque range ( $\pm 0$ - ... Nm)	Spring constant (N)	Rated axial load (N)	Overload capacity
DRT1	2	175	290	100 %
	5	330	290	100 %
	10	510	290	100 %
	12	550	290	100 %
	20	820	290	100 %
DRT2	50	2040	430	100 %
	100	2830	430	100 %
	200	4070	430	100 %
	300	5150	430	100 %
DRT3	500	4070	8150	50%
	1000	6790	8150	50%
	2000	11300	8150	50%
	3000	14310	8150	50%
DRT4	4000	17670	27000	50%
	5000	20610	27000	50%
	6000	23370	27000	50%



## Mechanical Dimensions DRT1

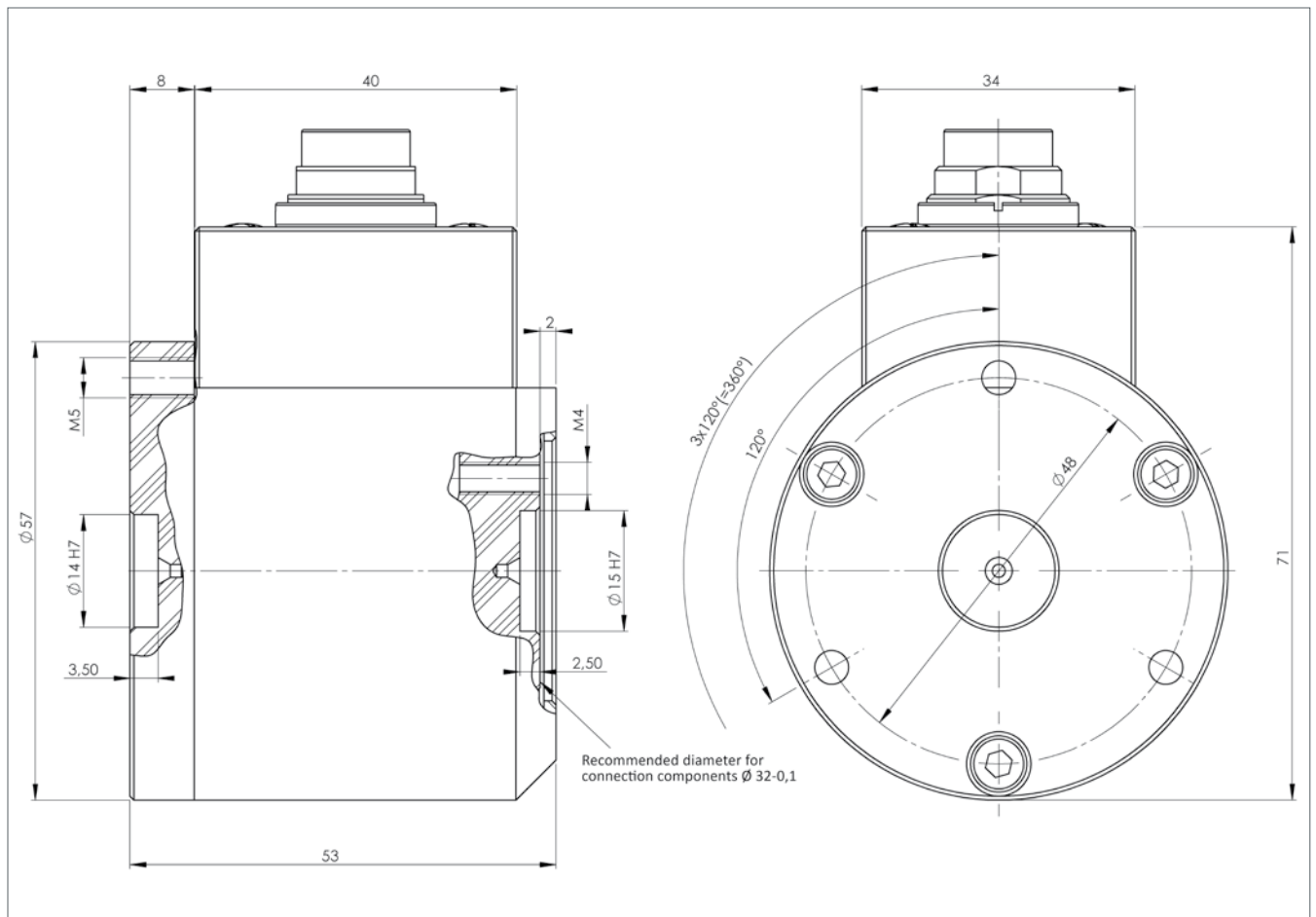

## Mechanical Dimensions DRT1 with Mounting Bracket

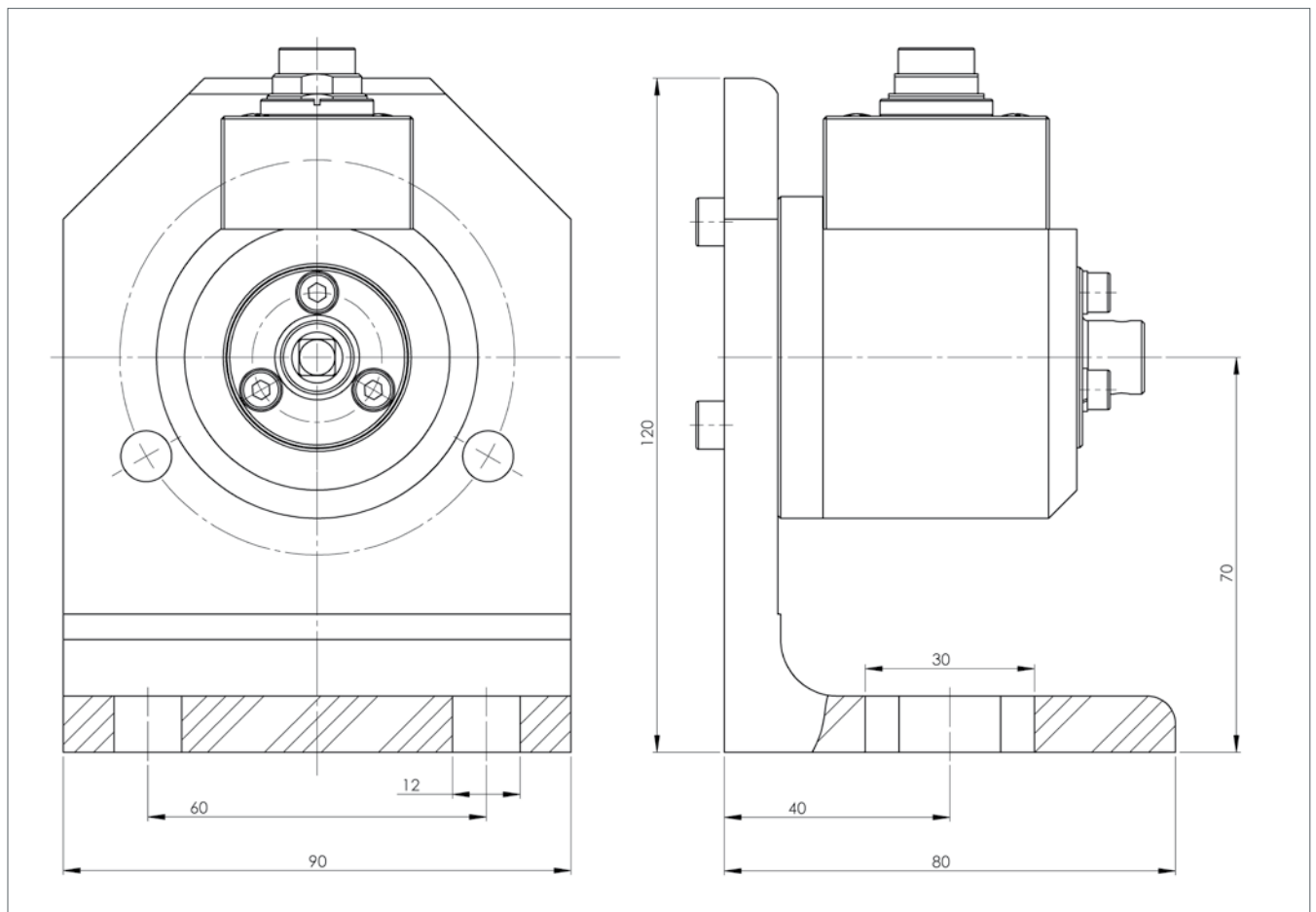

## Mechanical Dimensions DRT2

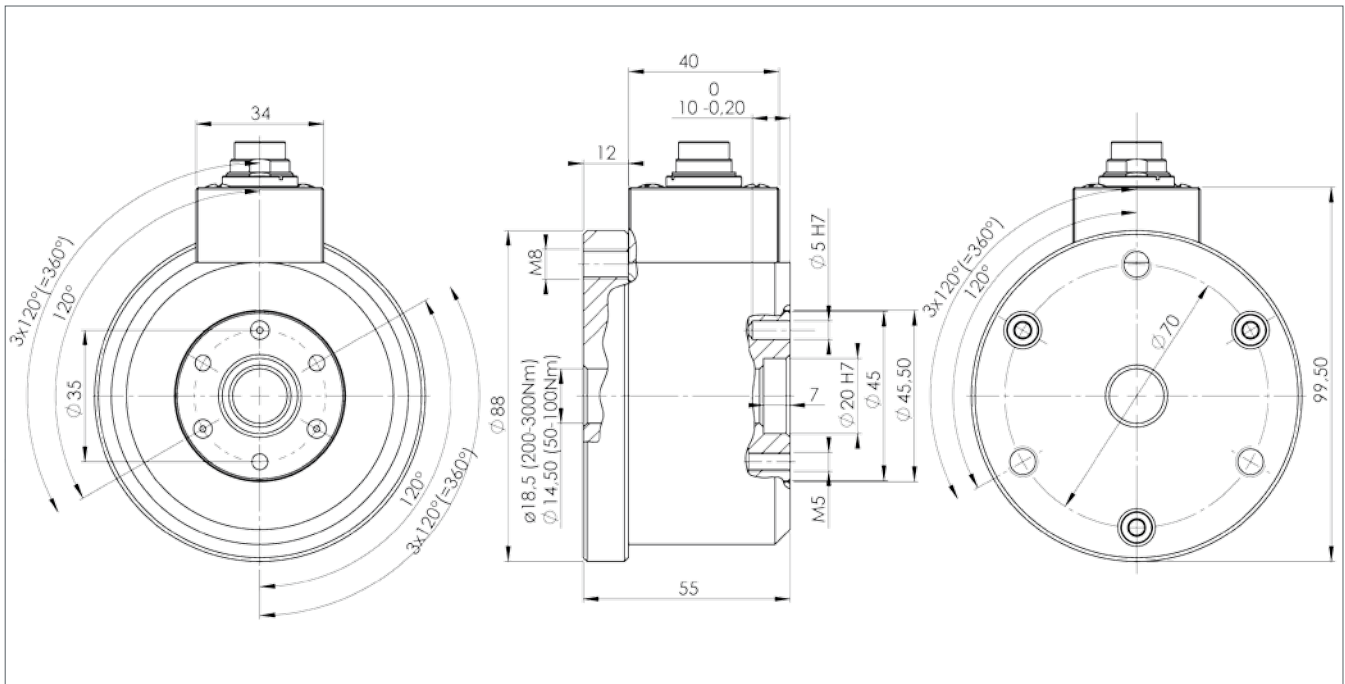

## Mechanical Dimensions DRT2 with Mounting Bracket and Adapter

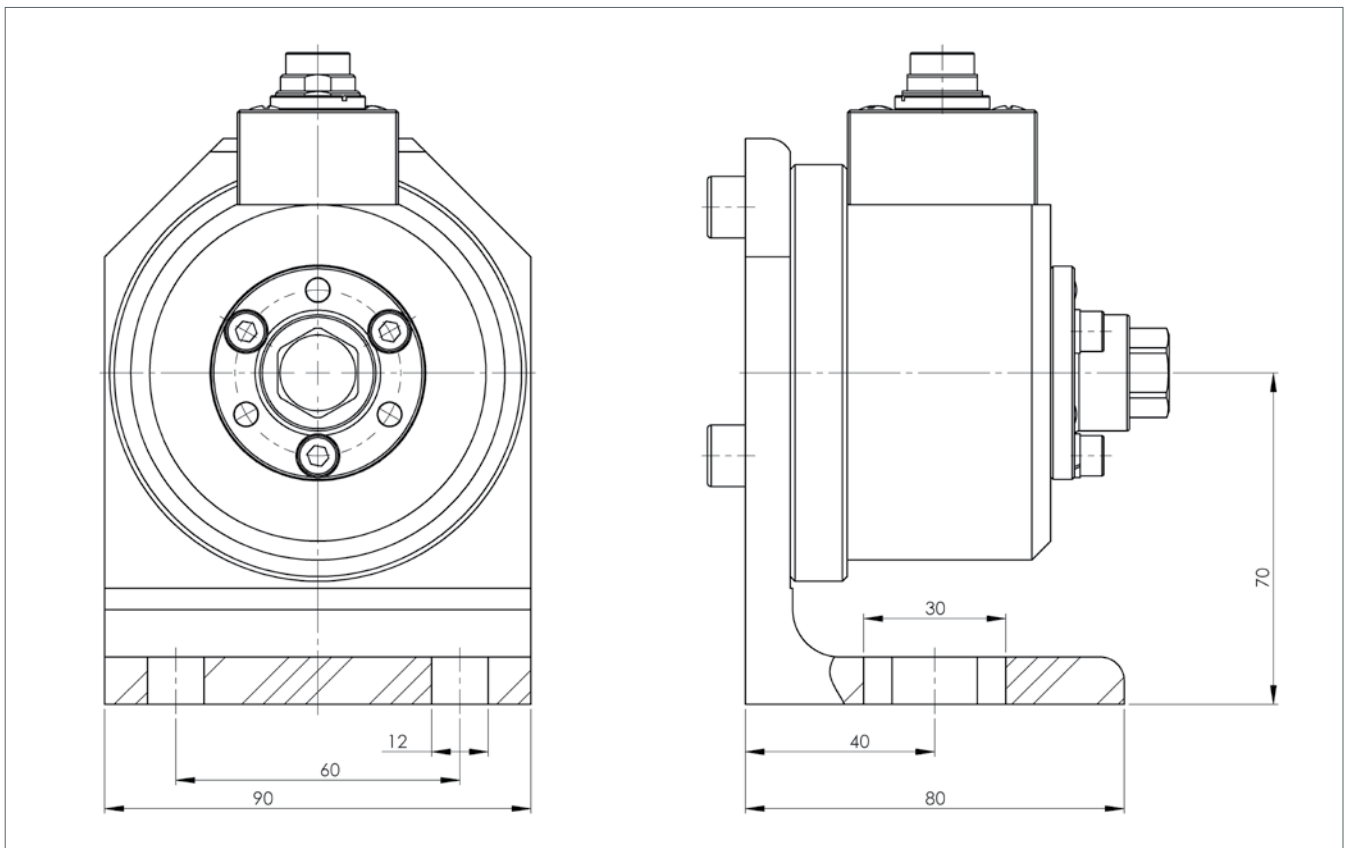

## Mechanical Dimensions DRT3

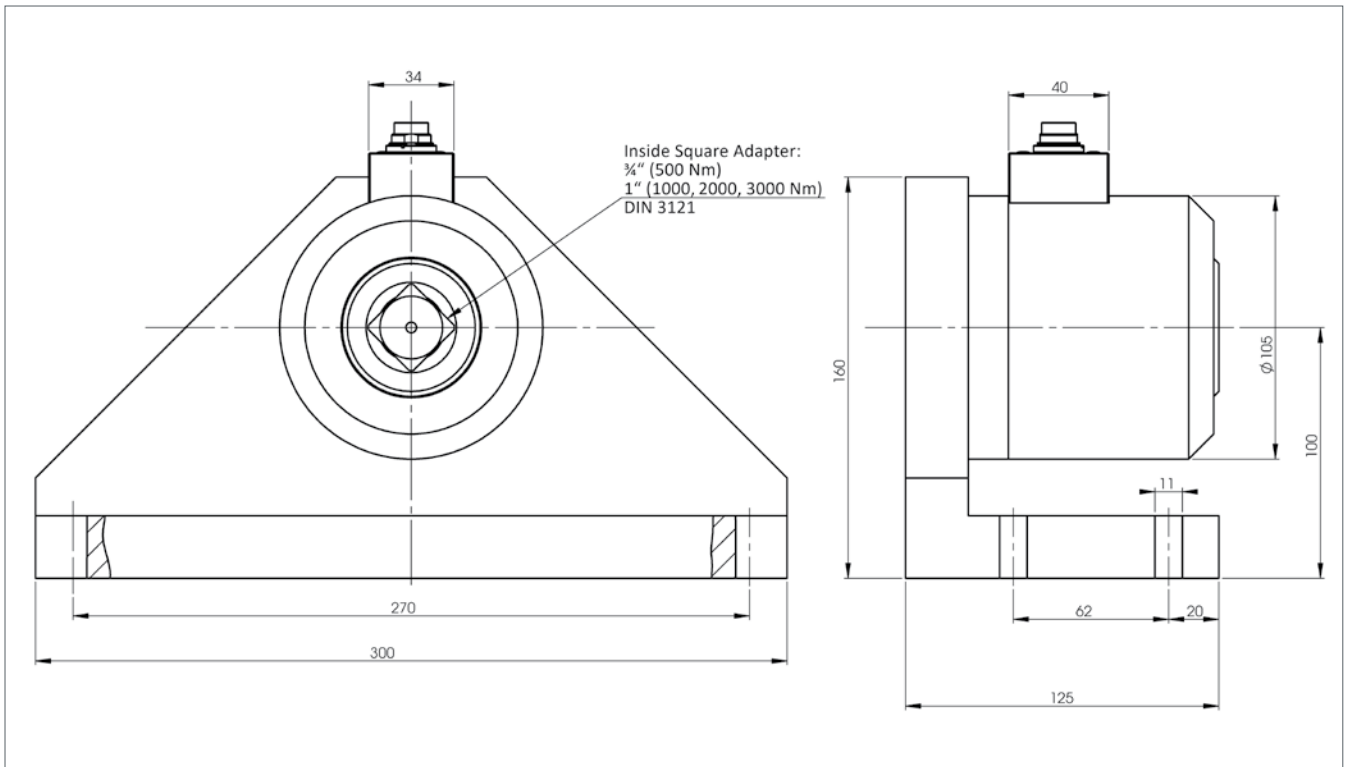

## Mechanical Dimensions DRT4

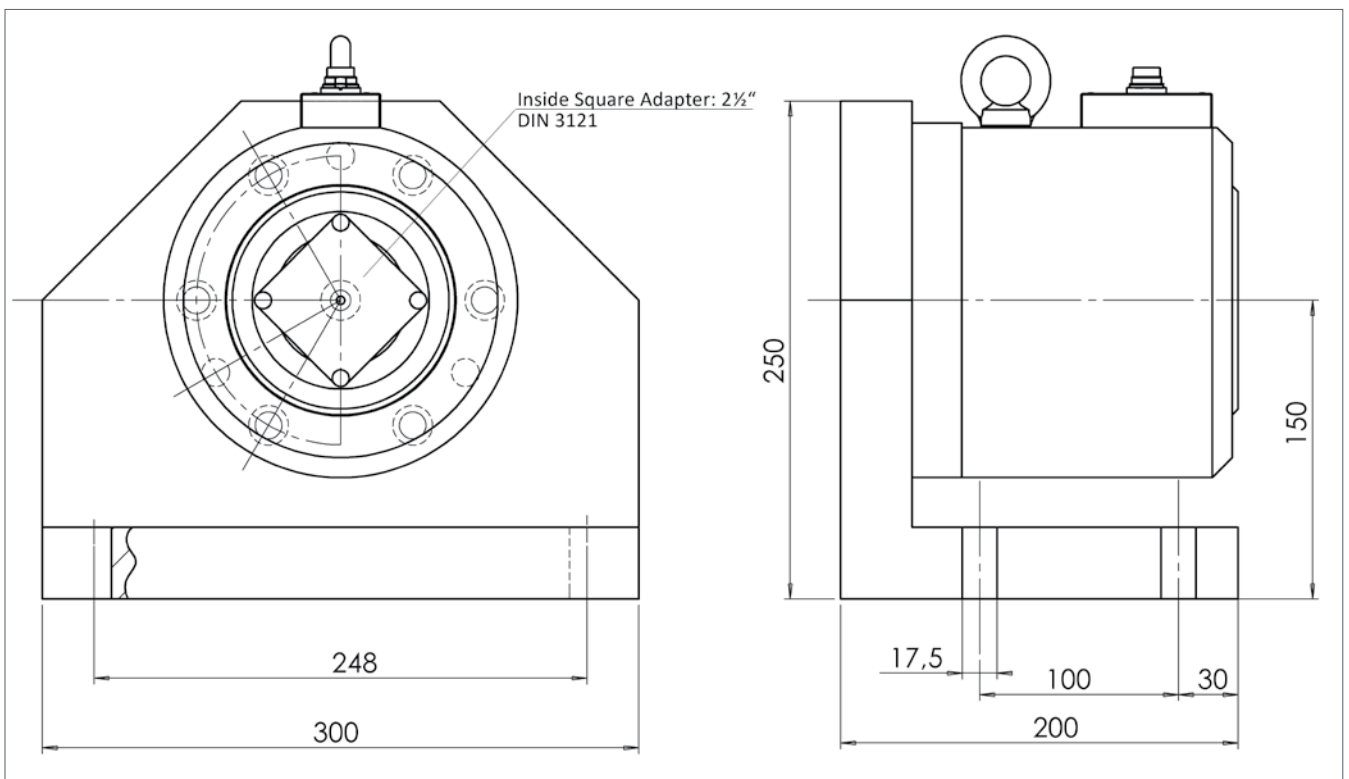

## Ordering code system

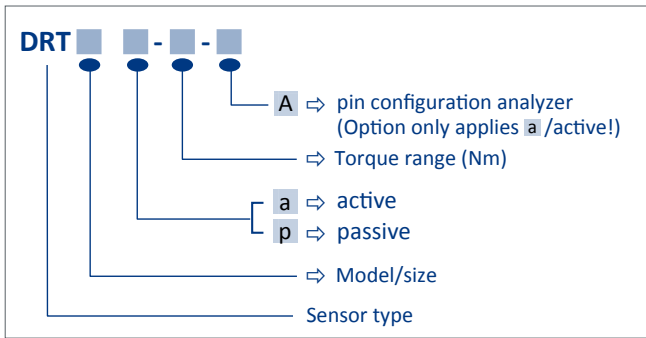

### Ordering Code Accessories DRT1

<b>DRT1-Mounting Bracket</b>
<b>Hexagon Adapter DIN ISO 272:</b>
DRT1 - SW 5,5
DRT1 - SW 7
DRT1 - SW 8
DRT1 - SW 10
DRT1 - SW 13
<b>Inside Square Adapter:</b>
DRT1 - 1/4" DIN 3121-H
DRT1 - 1/4" DIN 3121-without keyway

### Ordering Code Accessories DRT2

<b>DRT2-Mounting Bracket</b>	
<b>Hexagon Adapter DIN ISO 272:</b>	
DRT2 - SW 13	DRT2 - SW 14
DRT2 - SW 15	DRT2 - SW 16
DRT2 - SW 17	DRT2 - SW 18
DRT2 - SW 19	DRT2 - SW 20
DRT2 - SW 21	DRT2 - SW 22
<b>Inside Square Adapter:</b>	
DRT2 - 1/4" DIN 3121-H	
DRT2 - 3/8" DIN 3121-H	
DRT2 - 1/2" DIN 3121-H	
DRT2 - 1/4" DIN 3121 without keyway	
DRT2 - 3/8" DIN 3121 without keyway	
DRT2 - 1/2" DIN 3121 without keyway	

### Ordering Code Accessories DRT3

<b>DRT3-Mounting Bracket</b>
<b>Inside Square Adapter:</b>
DRT3 - 1" - 3/4"

### Ordering Code Accessories DRT4

<b>DRT4-Mounting Bracket</b>
------------------------------

## more Accessories

Cables

Analycers

Screwing Simulators

## Datasheet

### Reactive Torque Sensor

# DRW-K

#### Non rotating

19 torque ranges from  $\pm 0 - 0,5$  up to  $\pm 0 - 20.000$  Nm

- fixed cable
- integrated 100%-control
- wide range of applications
- no maintance
- keyway optional



This torque sensor is designed for non-rotating (static) applications.

Both static and dynamic measurements can be taken.

The strain-gauge-based sensor outputs a standardized output signal in mV/V that is proportional to the torque.

As these transducers are non-rotating and hence have no moving parts, they require no maintenance and do not wear.

Also available as an active device when combined with the DMSVE amplifier unit.

### Ordering code system

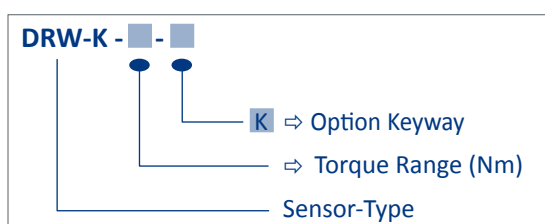

### Available Accessories

Supply and display unit: GMV2

ValueMaster<sub>base</sub>\*  
ValueView\*

Couplings

\* Only in combination with amplifier „DMSVE“

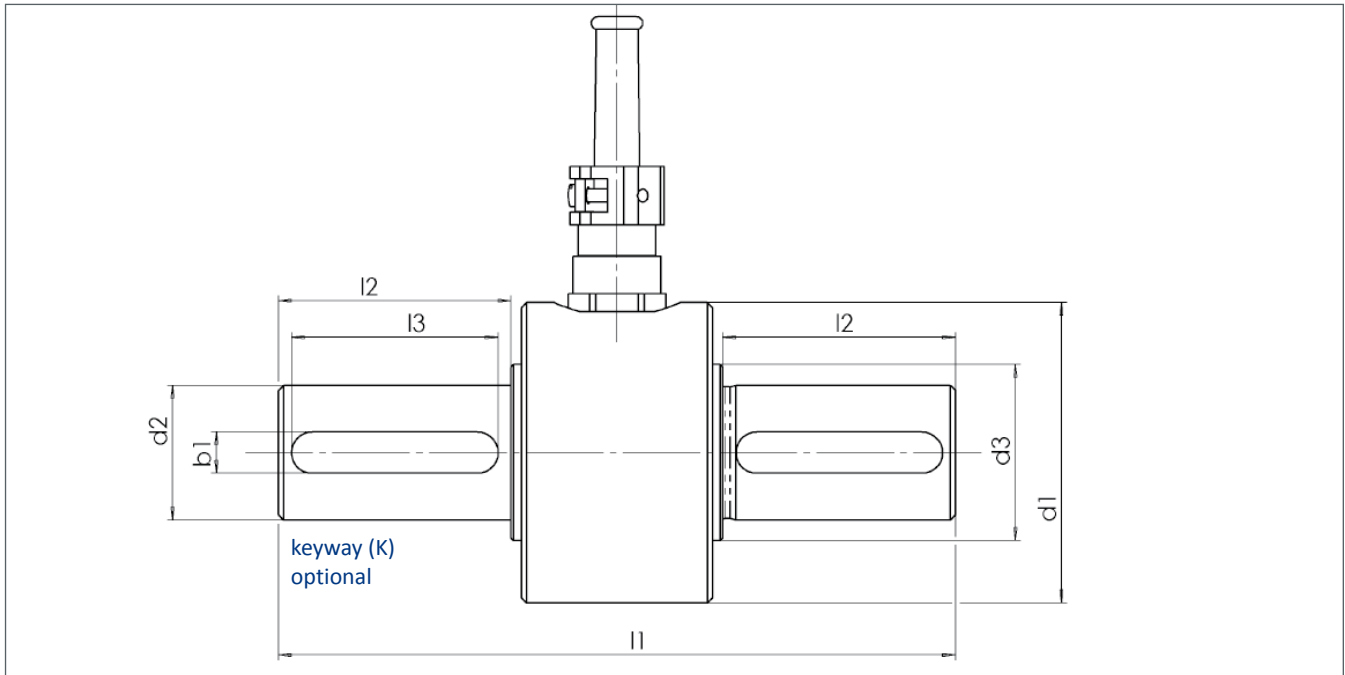

## Mechanical Dimensions DRW-K

Torque Ranges: $\pm 0 - \dots$		l1	l2	l3 (optional)	d1	d2	d3	b1 (optional)
0,5   1	Nm	47	10	–	24	8	12	-
2   5   10	Nm	58	12	8	38	12	18	4
15   20	Nm	74	20	16	38	12	18	4
50	Nm	104	35	28	50	18	26	6
100   200	Nm	131	45	40	58	26	34	8
500   1000	Nm	168	60	–	77	45	58	–
2   3   4   5	kNm	264	110	–	98	70	–	–
10   15   20	kNm	285	115	–	138	110	–	–

General tolerances DIN 2768-m

## Electrical Spezifications DRW-K

Supply voltage:	12 V DC max.
Current consumption:	35 mA max.
Measurement signal:	1 mV / V ( $\pm 0,25\%$ )
Nonlinearity:	< 0,1 %
Hysteresis:	< 0,1 %
Deviation at zero point:	$\leq \pm 0,01$ mV/V
Internal resistance:	350 $\Omega$ nominal
Compensated temperature range:	5 - 45 °C
Operating temperature:	0 - 60 °C
Temperature error	
Zero point:	0,02 % / K
Sensitivity:	0,01 % / K
Mechanical overload:	100 %
Internal protection:	IP40
Connection:	6pin-connector, coupling plug is included
Cable length:	2,5 m
Factory calibration right-/left load in 25% steps. Special calibration on request.	

## Datasheet

### Torque Transducer

# DRB-I

3 torque ranges from  $\pm 0 - 0,2$  up to  $\pm 0 - 1$  Nm  
for static applications

### Features DRB-I

- insensitive by axial and radial forces
- no maintenance needed
- single supply voltage
- suitable for very low torques
- integrated overload protection



This transducer is designed for static, non-rotating torque measurement. It can resist axial and radial forces. It outputs a high signal even at low torques.

### Ordering code system

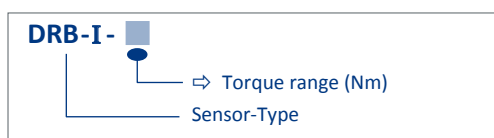

### Available Accessories

Supply and display unit: GMV2  
ValueMaster<sub>base</sub>\*  
ValueView\*

Cables  
Couplings

\* Only in combination with amplifier „DMSVE“

## Mechanical Dimensions DRB-I

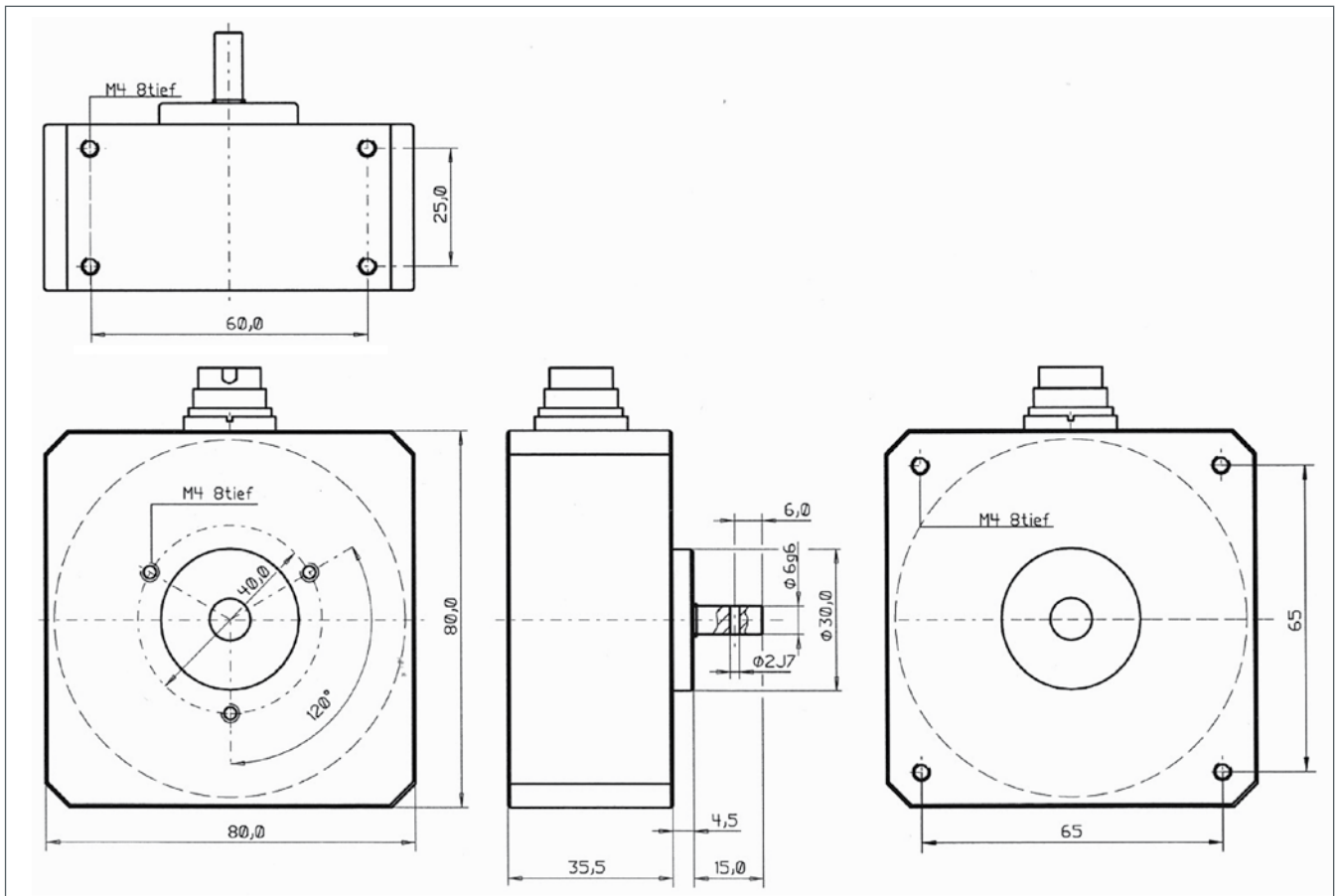

## Electrical Specifications DRB-I

Torque ranges: ( $\pm 0 - \dots$ Nm)	0,2   0,5   1
Supply voltage:	12 V max.
Power consumption:	35 mA max.
Voltage output:	2 mV / V
Nonlinearity:	0,15 %
Hysteresis:	0,1 %
Deviation at zero point:	$\leq \pm 0,02$ mV/V
Internal resistance::	350 $\Omega$ nominal
Compensated temperature range:	5 - 45 °C
Operating temperature:	0 - 60 °C
Temperature error	
Zero point:	0,02 % / K
Sensitivity:	0,01 % / K
Mechanical overload:	0,2 Nm: 400 % 0,5 Nm: 200 % 1 Nm: 100 %
Load rating:	axial 25 N radial 50 N
Weight:	approx. 600 g
Internal protection:	IP40
Connection:	6pin-connector
Calibration:	Works certificate with 25% steps cw and ccw. Other calibrations upon request.



## Datasheet

### Torque Transducer

# DRB-II

3 torque ranges from  $\pm 0 - 5$  up to  $\pm 0 - 20$  Nm  
for static application



### Features DRB-II

- insensitive by axial and radial forces
- extremely rugged construction
- integral overload protection
- in active and passive version

The DRB-II transducer was developed to measure non-rotating torques that are free of axial and flexural forces.

It is primarily deployed in applications where a high safety factor against overload is needed. The device is not affected by axial and flexural forces.

### Ordering code system

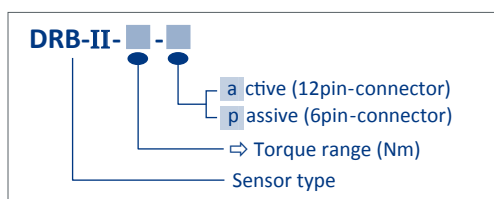

### Available Accessories

Supply and display unit: GMV2  
ValueMaster<sub>base</sub>\*  
ValueView\*

Cables  
Couplings

\* Only for active Model

## Mechanical Dimensions DRB-II

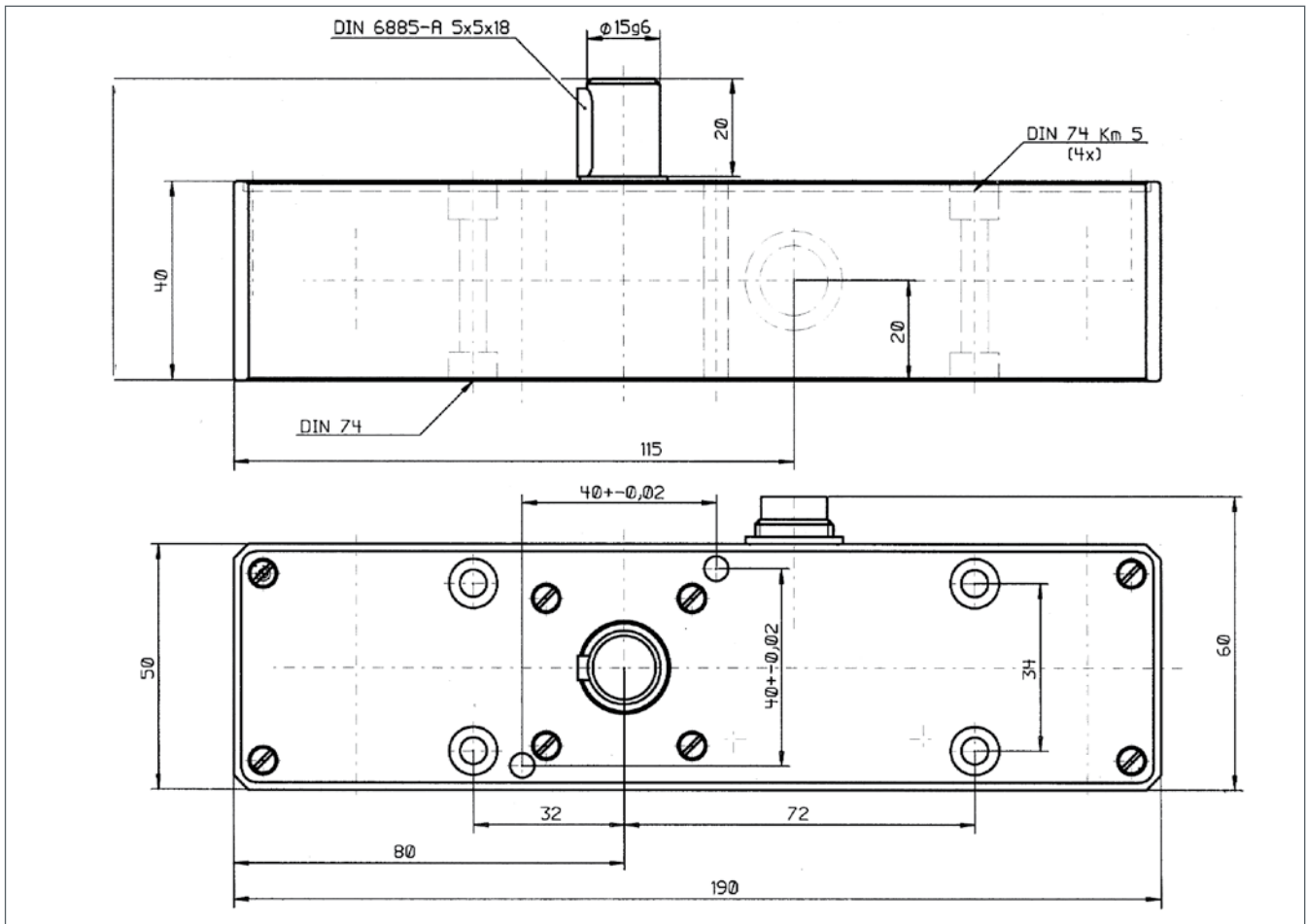

## Electrical Specifications DRB-II

Model	(a)ctive	(p)assive
Torque ranges: ( $\pm 0 - \dots$ Nm)	5   10   20	5   10   20
Supply voltage:	12 V DC $\pm 10 \%$	12 V max.
Power consumption:	approx. 35 mA	35 mA max.
Rise time 10 - 90 %:	1 ms (1kHz)	—
Voltage output:	$0 \pm 5$ V at $> 10$ k $\Omega$	2 mV / V
Nonlinearity:	0,2 %	0,2 %
Hysteresis:	0,2 %	0,2 %
Deviation at zero point:	$\leq \pm 100$ mV	$\leq \pm 0,02$ mV / V
Internal resistance:	—	350 $\Omega$ nominal
Compensated temperature range:	5 - 45 °C	5 - 45 °C
Operating temperature:	0 - 60 °C	0 - 60 °C
Temperature error		
Zero point:	0,02 % / K	0,02 % / K
Sensitivity:	0,01 % / K	0,01 % / K
Mechanical overload:	500 %	500 %
Weight:	approx. 950 g	approx. 950 g
Internal protection:	IP40	IP40
Connection:	12pin-connector	6pin-connector
Calibration: Works certificate with 25% steps cw and ccw. Other calibrations upon request.		

## Datasheet

### Torque Transducer

**DRDML**  $\pm 0 - 0,5$  up to  $\pm 0 - 20$  Nm

**DRDMS**  $\pm 0 - 0,5$  up to  $\pm 0 - 20$  Nm

**DRDMN**  $\pm 0 - 10$  up to  $\pm 0 - 50$  Nm

with mechanical coupling for maxon gears  
with contact-less data acquisition  
as a complete drive and torque measuring unit

Test bench construction  
Bolting technology



## Electrical Specifications

Supply voltage:	12 V DC $\pm 10$ %
Power consumption:	approx. 120 mA
Rise time 10-90 %:	1 ms (1 kHz)
Voltage output:	0 $\pm 10$ V
Internal resistance:	100 $\Omega$
Ripple:	< 100 mVss
Nonlinearity:	< 0,15 %
Hysteresis:	< 0,1 %
Deviation an zero point:	$\leq \pm 100$ mV
Operating temperature:	0 - 60 °C
Compensated temperature range:	5 - 45 °C
Temperature error	
Zero point:	0,02 %/K
Sensitivity:	0,01 %/K
Mechanical overload:	100 %
Connection:	2,5 m connection cable with flying leads
Calibration: Works certificate with 25% steps cw and ccw. Other calibrations upon request.	

## Mechanical Dimensions DRDML; cylindrical shaft ends

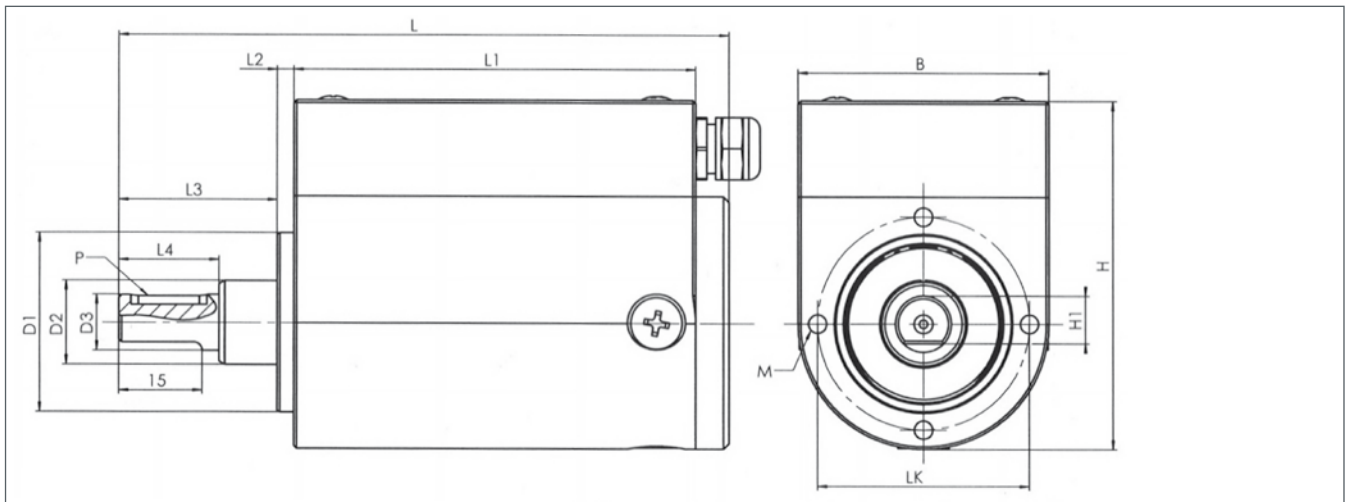

Model	DRDML-26 *	DRDML-42
Suitable for gear	GP26B	GP42C
Torque ranges ( $\pm 0$ - ... Nm)	0,5   1   2	5   10   15   20
<b>Dimensions</b>		
L (mm)	73,5	109,4
B (mm)	26	45
H (mm)	38	62
$\varnothing$ D1 (mm)	16,5	32
$\varnothing$ D2 (mm)	8	15
$\varnothing$ D3 (mm)	5	10
L1 (mm)	56	72
L2 [mm]	2	3
L3 [mm]	13,5	28,4
L4 (mm)	12,8	18
L5 (mm)	12,8	---
H1 (mm)	4,5	---
$\varnothing$ LK (mm)	20	38
M (mm)	M3 x 5 deep	M4 x 6 deep
P (DIN 6885)	---	A3 x 3 x 14
	(other ranges upon request; general tolerances DIN 2768-m)	
Weight approx. (g)	120	740
Speed max. (min <sup>-1</sup> )	25.000	10.000
*additional electronics integrated in the measuring cable		

## Technical Specifications DRDML

Model	Spring constant C (Nm/rad)	Mass moment of inertia J (g•cm <sup>2</sup> )	Rated axial load (N)	Rated radial load(N)
DRDML-26-0,5	110	1,3	190	6
DRDML-26-1	110	1,3	190	6
DRDML-26-2	250	1,3	190	12
DRDML-42-5	860	149	565	85
DRDML-42-10	1940	149	565	171
DRDML-42-15	2880	149	565	253
DRDML-42-20	3725	150	565	340

## Mechanical Dimensions DRDMS; 1/4 hexagon standard

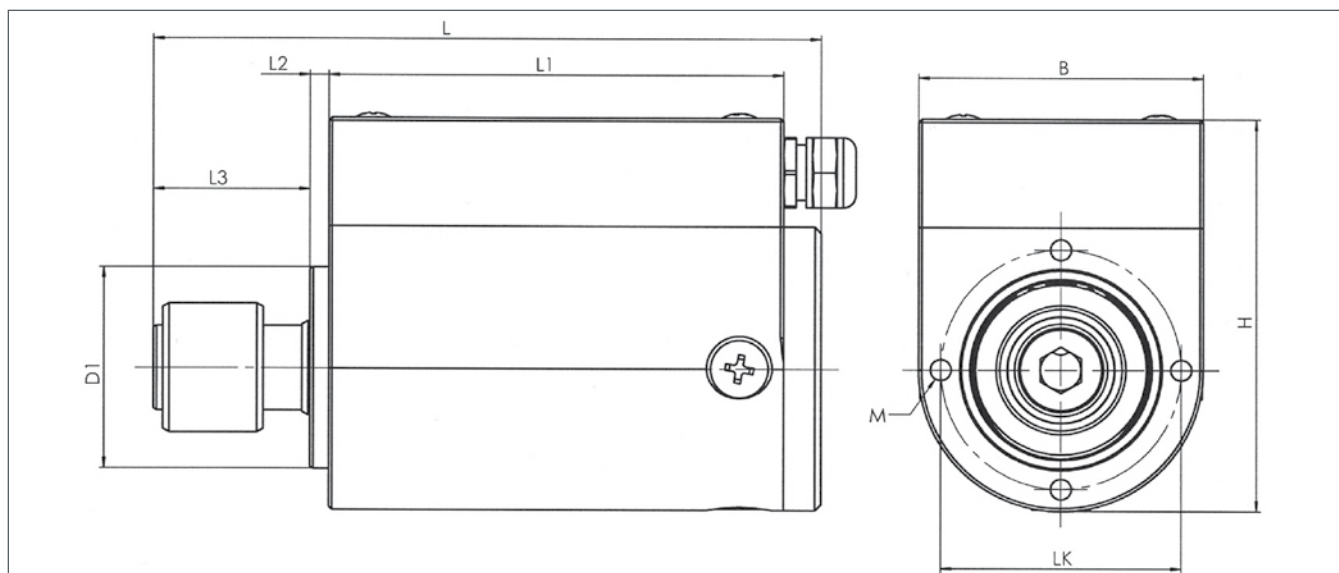

Model	DRDMS-22 *	DRDMS-32	DRDMS-42
Suitable for gear	GP22A	GP32A	GP42C
Torque ranges: ( $\pm 0$ - ... Nm)	0,5   1	1   2   5	5   10   15   20
<b>Dimensions</b>			
L (mm)	91	86,3	109,4
B (mm)	22	32	45
H (mm)	35,5	49	62
$\varnothing$ D1 (mm)	19	22	32
L1 (mm)	55	60	72
L2 (mm)	2	2	3
L3 (mm)	34	26,3	28,4
$\varnothing$ LK (mm)	14	26	38
M (mm)	M2 x 4 deep (3 x 180°)	M3 x 5 deep	M4 x 6 deep
	(other ranges upon request; general tolerances DIN 2768-m)		
Weight approx. (g)	130	320	740
Speed max. (1/min)	25.000	20.000	10.000
*additional electronics integrated in the measuring cable			

## Technical Specifications DRDMS

Model	Spring constant C (Nm/rad)	Mass moment of inertia J ( $g \cdot cm^2$ )	Rated axial load (N)	Rated radial load (N)
DRDMS-22-0,5	90	0,5	90	6
DRDMS-22-1	90	0,5	90	6
DRDMS-32-1	270	5	230	8
DRDMS-32-2	270	5	230	8
DRDMS-32-5	700	5	230	20
DRDMS-42-5	880	60	320	20
DRDMS-42-10	2050	60	320	38
DRDMS-42-15	3100	60	320	55
DRDMS-42-20	4100	60	320	75

## Mechanical Dimensions DRDMN; square standard

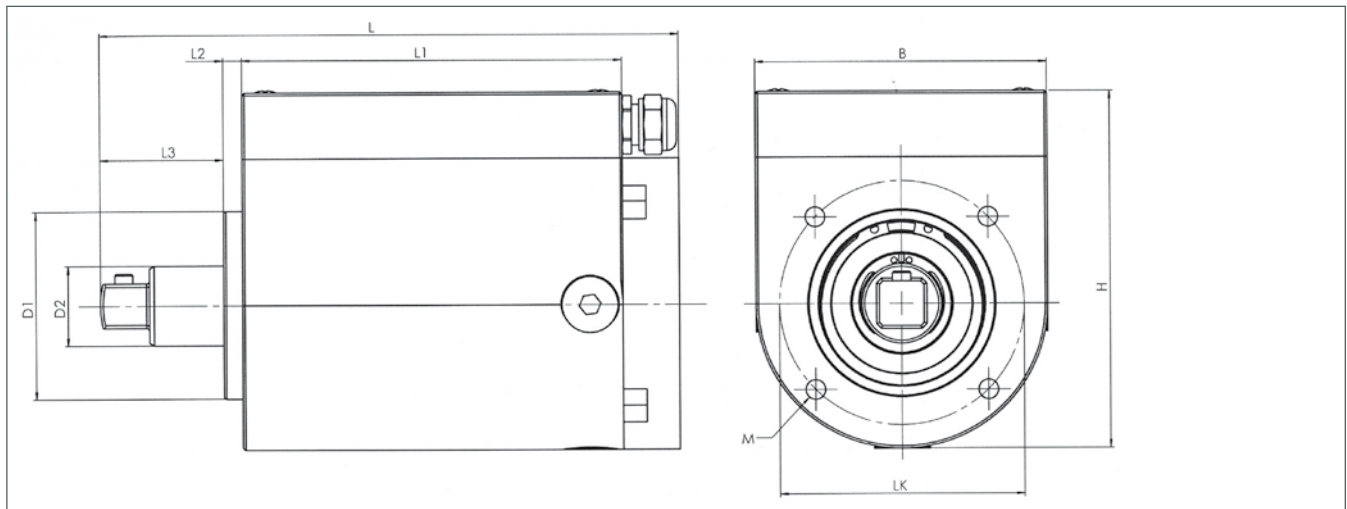

<b>Model</b>	<b>DRDMN-62</b>
Suitable for gear	GP62
Square	3/8"
Torque ranges ( $\pm 0 - \dots$ Nm)	10   20   50
<b>Dimensions</b>	
L (mm)	123,4
B (mm)	62
H (mm)	76
$\varnothing$ D1 (mm)	40
$\varnothing$ D2 (mm)	17
L1 (mm)	81
L2 (mm)	4
L3 (mm)	26,4
$\varnothing$ LK (mm)	52
M (mm)	M5 x 10 deep
(other ranges upon request; general tolerances DIN 2768-m)	
Weight approx. (g)	1000
Speed max. (1/min)	10.000

## Technical Specifications DRDMN

Model	Spring constant C (Nm/rad)	Mass moment of inertia J ( $g \cdot cm^2$ )	Rated axial load (N)	Rated radial load (N)
DRDMN-62-10	2200	130	1300	35
DRDMN-62-20	4300	130	1300	70
DRDMN-62-50	8000	130	1300	190

## Ordering code system

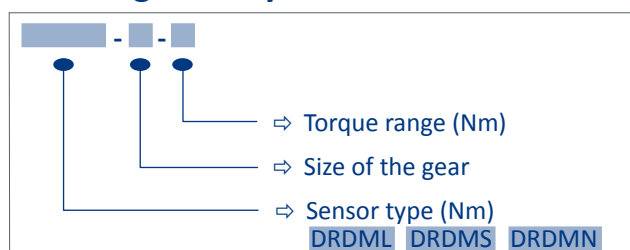

## Available Accessories

Supply and display unit ValueMaster<sub>base</sub>  
 Motor and gears on demand  
 Complete testing device

## Datasheet

### Torque Transducer

# DRN ¼" - 1"

5 torque ranges from  $\pm 0 - 2$  Nm up to  $\pm 0 - 1000$  Nm

for static applications

active oder passive-model

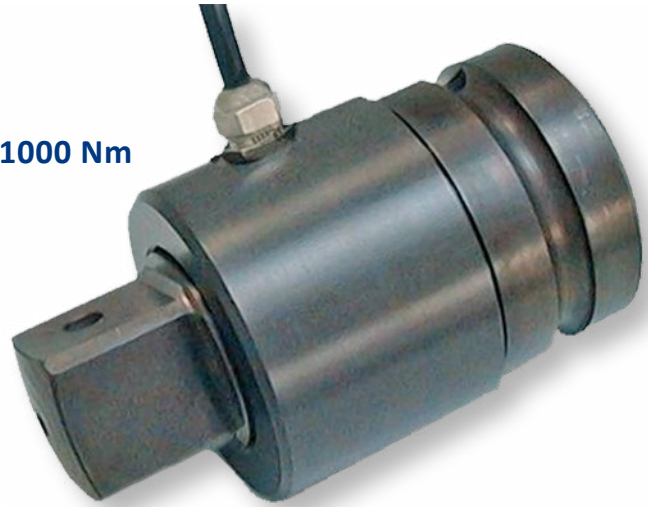

### Features

- accuracy 0,15 % full scale
- protection IP50
- square drive DIN3121
- input for checking the device chain

### suitable for

- testing torque wrenches
- precisely tightening screws
- measurement of screwings on badly re achable places
- measuring torque on screwings that are hard to reach
- measuring the friction factor
- measuring the load on flap valve drives max 2 turns

This non-rotating torque transducer is suitable for checking different types of screwing tools or for use as a reference transducer in test benches. It is a low-cost alternative to the rotating torque

transducer. When the supply voltage is input to the transducer and the transducer is not loaded a control signal is output which can be used to adjust the chain.

## Electrical Specifications DRN ¼" - 1"

Model:	(p)assive	Option (a)ctive standard GMV2
Supply voltage:	12 V max.	12 V ± 10 %
Power consumption:	17 mA max.	approx. 20 mA
Voltage output:	approx. 1 mV / V	0 - ± 5 V
Nonlinearity:	0,15 %	0,15 %
Hysteresis:	0,1 %	0,1 %
Deviation at zero point:	≤ ± 0,01 mV / V	≤ ± 100 mV
Internal resistance:	700 Ω nominal	--
Compensated temperature range:	5 - 45 °C	5 - 45 °C
Operating temperature:	0 - 60 °C	0 - 60 °C
Temperature error		
Zero point:	0,02 % / K	0,02 % / K
Sensitivity:	0,01 % / K	0,01 % / K
Mechanical overload:	40 %	40 %
Internal protection:	IP 50	IP 50
Connection:	flying leads	12pin-connector
Cable lenght:	2,5 m	2,5 m
Amplifier integrated in the cable		
Calibration: Works certificate with 25% steps cw and ccw. Other calibrations upon request.		

## Mechanical Dimensions DRN ¼" - 1"

Model	DRN ¼"	DRN ⅜"	DRN ½"	DRN ¾"	DRN 1"
Torque ranges: (± 0 - ...Nm)	2   5   10   12   15   20	20   30   50   63	100   160   200	200   300   500	1000
<b>Dimensions:</b>	(other ranges upon request; General tolerances DIN 2768-m)				
A (mm)	45	53	65	90	100
B (mm)	7,2	10,5	15,1	22,6	27,5
C (mm)	9,8	12,5	16	24,4	29,5
D (mm)	∅ 30	∅ 35	∅ 45	∅ 55	∅ 64
E (mm)	6,35	9,525	12,7	19,05	25,4
square DIN 3121 outside and inside	¼"	⅜"	½"	¾"	1"
Weight (approx.) g	60	120	270	640	1000

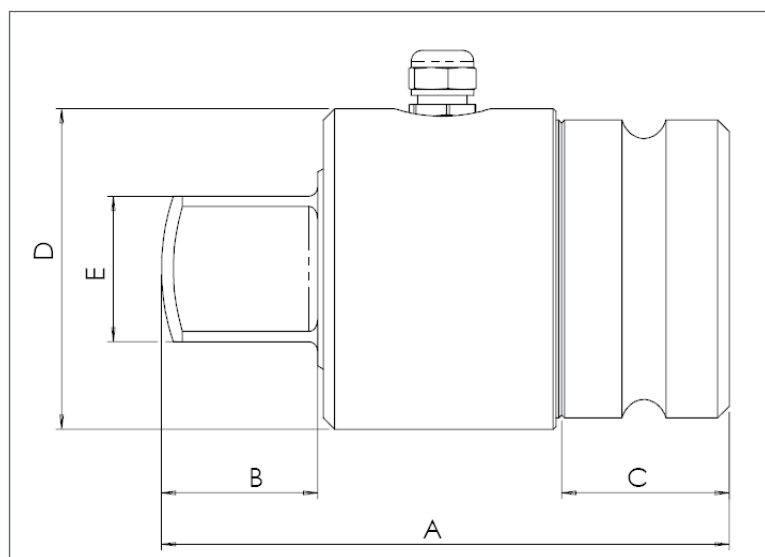

### Available Accessories

Measuring cable extension  
Supply and display unit  
Adapter

### Ordering code system

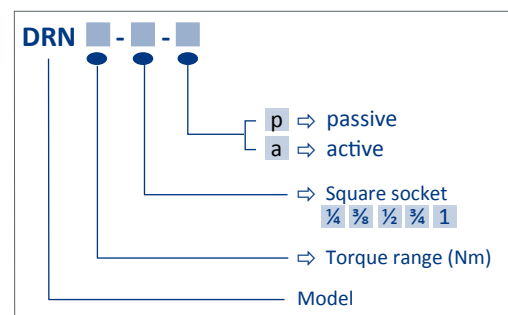



## Datasheet

### Torque Transducer

# DRN 1½" - 2½"

DRN 1½": 4 torque range up to  $\pm 0 - 5000$  Nm

DRN 2½": 3 torque range up to  $\pm 0 - 20.000$  Nm

for static applications

active oder passive-model



### Features

- lateral force insensitive
- accuracy 0,15 % full scale
- Degree of protection optionally  
IP50 (dust-protected) or IP55 (jet-proof)
- square DIN 3121

### suitable for

- non-rotating applications
- test facilities
- torque reference recording

### Electrical Specifications DRN 1½" - 2½"

Model:	(p) assive	Option (a)ctive standard GMV2
Supply voltage:	12 V max	12 V DC $\pm 10$ %
Power consumption:	17 mA max.	ca. 20 mA
Measurement signal:	2 mV / V	0 - $\pm 5$ V
Nonlinearity:	0,15 %	0,15 %
Hysteresis	0,1 %	0,1 %
Deviation at zero point:	$\leq \pm 0,01$ mV / V	$\leq \pm 100$ mV
Internal resistance:	700 $\Omega$ nominal	---
Compensated temperature range:	5 - 45 °C	5 - 45 °C
Operating temperature:	0 - 60 °C	0 - 60 °C
Temperature error		
Zero point:	0,02 % / K	0,02 % / K
Sensitivity:	0,01 % / K	0,01 % / K
Mechanical overload:	50 %	50 %
Internal protection:	IP50 or IP55	IP50 or IP55
Connection:	6pin- connector	12pin- connector
Calibration: Works certificate with 25% steps cw and ccw. Other calibrations upon request.		

## Mechanical Dimensions DRN 1½" - 2½"

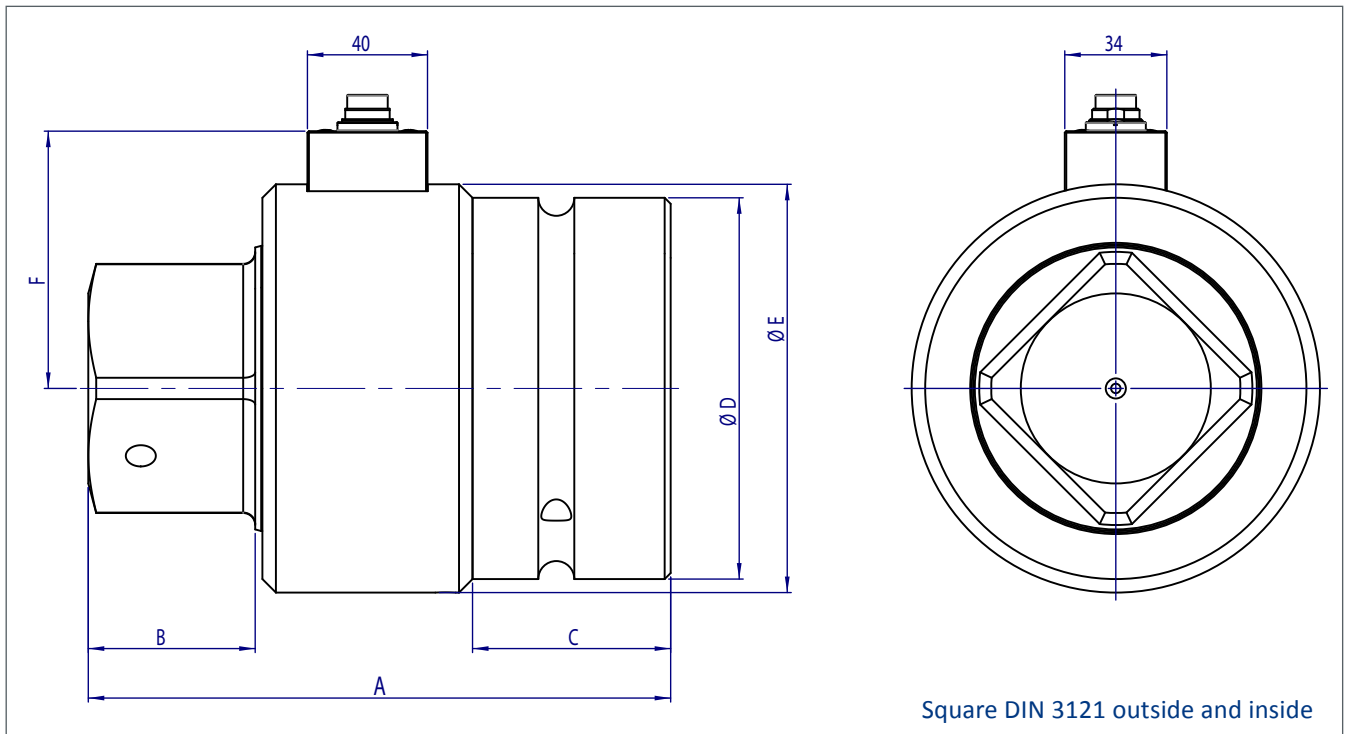

Square DIN 3121 outside and inside

Model	DRN 1½"	DRN 2½"
Torque ranges: (± 0 - ... Nm)	2000   3000   4000   5000	10.000   15.000   20.000
<b>Dimensions:</b>	(other ranges upon request; General tolerances DIN 2768-m)	
A (mm)	162	194
B (mm)	39,3	55,6
C (mm)	50	66
D (mm)	∅ 70	∅ 127
E (mm)	∅ 80	∅ 136
F (mm)	56,2	85,7
Square DIN 3121 outside and inside	1½"	2½"
Weight (approx.) g	3000	11.000

## Ordering code system

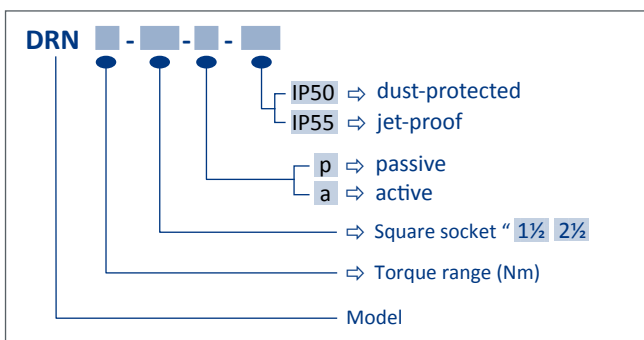

## Available Accessories

Measuring cable extension  
Supply and display unit  
Adapter

## Datasheet

### Test Bench for hydraulic tools

# PH

4 Measurement ranges from  $\pm 0 - 3$  up to  $\pm 0 - 20$  kNm

#### Suitable for:

- adjusting and testing tools before screwing
- inspection as per DIN EN ISO 9000ff
- tabulating the relation of working pressure to torque
- portable test bench

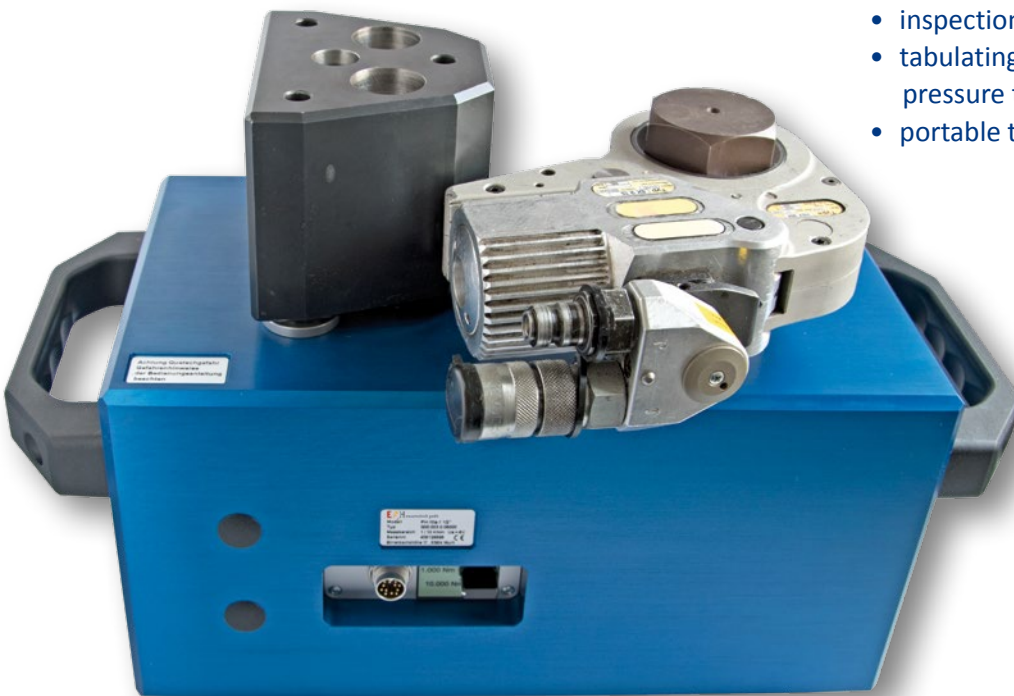

Delivery without test object, adapter or counterpart

With the model PH test bench it's easy to adjust and test hydraulic tools; tabulate the relation of working pressure to torque; and check the performance of tools.

Measurements can be displayed and documented with the supply and display unit GMV2. Tools with driving squares compliant with DIN 3121 can be plugged in directly.

We supply a range of adapters for the different tools. Tools for hexagon bolts can be connected with various hexagonal adapters (refer to the "PH hexagonal adapters" specification sheet).

## Technical Specifications PH

Measurement range: ( $\pm 0 - \dots$ kNm)	3   10   16   20	
Type:	(a)ctive	(p)assive
Supply voltage:	12V DC $\pm 10\%$	12 V max.
Power consumption:	ca. 20 mA	35 mA max.
Voltage output:	$0 \pm 5$ V	2 mV/V
Nonlinearity:	< 0,5 %	< 0,5 %
Hysteresis:	< 0,1 %	< 0,1 %
Deviation at zero point:	$\leq \pm 100$ mV	$\leq \pm 0,01$ mV/V
Internal resistance:	---	350 $\Omega$ nominal
Compensated temperature range:	5 - 45 °C	5 - 45 °C
Operating temperature:	0 - 60 °C	0 - 60 °C
Temperature error		
Zero point:	0,02 % / K	0,02 % / K
Sensitivity:	0,01 % / K	0,01 % / K
Mechanical overload:	50 %	50 %
Weight		
3 kNm + 10 kNm:	approx. 41 kg	approx. 41 kg
16 kNm + 20 kNm:	approx. 90 kg	approx. 90 kg
Connection:	12pin-connector	6pin-connector
Internal protection:	IP40	IP40
Calibration: Factory certificate in 25 % steps in cw. Special calibration on request.		

## Mechanical Dimensions PH

Measurement range ( $\pm 0 - \dots$ kNm)	3   10	16   20
L (mm)	464	571
B (mm)	210	250
H (mm)	259	374
Inside square::	1 ½"	2 ½"
Counterpart:	Accessories; can be customized	

General tolerances DIN 2768-m

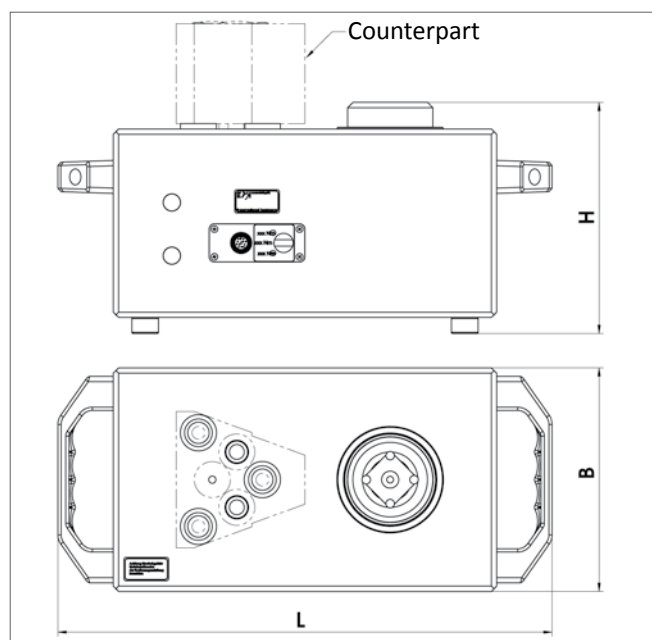

## Ordering Code

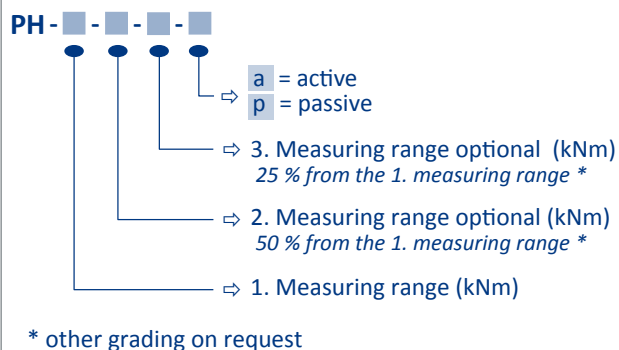

## Available Accessories

Adapter  
 Counterpart  
 Cables  
 Supply and display unit GMV2

## SELECTION OF REALIZED PROJECTS

### Torque Sensors Customized / Special Production

A selection of our custom sensors are described here. We have our own manufacturing facilities where we manufacture a high percentage of our components and run our own strain-gauge applications. This allows us to respond rapidly and with great flexibility to your project requirements.

	<p><b>DRFSB</b></p> <p>± 0 - 5 Nm</p>	<p><b>Custom order for test lab</b></p> <p>Torque transducer suitable for impact drilling machines. The shaft in the machine is replaced by a shaft modified by us. The angle of rotation measurement is implemented via the gear-wheel. The resolution depends on the number of teeth.</p>
	<p><b>DRWPO</b></p> <p>± 0 - 5 Nm</p>	<p><b>Special order for bottling plant in the medical-technical field</b></p> <p>Torque sensor for closing system with through-hole for compressed air. Sensor in IP67, hydrogen peroxide (H<sub>2</sub>O<sub>2</sub>) - resistant.</p>
		<p>additionally highly polished</p>
	<p><b>DRPO</b></p> <p>± 0 - 5 Nm</p>	<p>Custom order for closing system in the medical-technical field. Through hole for compressed air.</p>
	<p><b>DRFIS</b></p> <p>± 0 - 30 Nm</p>	<p>Both sides with hexagon socket, housing with flange for drive.</p>
	<p><b>DRHI</b></p> <p>± 0 - 4 Nm</p>	<p>Torque transducer for percussion drill.</p>

## SELECTION OF REALIZED PROJECTS

### Torque Sensors Customized / Special Production

	<p><b>DREC</b></p> <p>± 0 - 50 Nm</p>	<p>Custom torque transducer for a test bench.</p>
	<p><b>KBW</b></p> <p>± 700 - 6000 Nm</p>	<p>Special transducer for a test stand.</p> <p>Attachment torque transducer for torque power screw.</p>
	<p><b>DRFL</b></p>	<p>Sensor of the DRFL series in special housing with short shaft.</p>
	<p><b>DRB</b></p> <p>± 0 - 2 Nm</p>	<p>DRB in special housing with small dimensions.</p>
	<p><b>PHE</b></p> <p>± 35 - 250 Nm</p>	<p>Attachment torque transducer for compressed air pulse tools.</p>
	<p><b>MPS</b></p> <p>± 0 - 20 Nm</p>	<p>Torque transducer for monitoring of flaps on aircraft.</p>

## Datasheet

### Measurement module with network connection

# ValueMaster<sub>base</sub>

- Measurement of torque, speed, angle of rotation, pressure, force or stroke
- Sockets for 2 sensors
- Control I/O port with output for PLC, for example
- Test operation on PC using software supplied by ETH
- Network connection via Ethernet
- with scope function
- Analog output  $\pm 10$  V for direction of rotation and drive speed setpoint



#### The ValueMaster measurement module turns your PC or Notebook into a full-fledged professional measurement device:

- Measurements can be displayed, evaluated according to preset limits and assessed graphically.
- Data from torque transducers with integrated ID chips are automatically loaded into the parameter set.
- Measurements are stored in a txt file. They can be compared at many levels in the archive.
- The device can be controlled externally via control inputs.
- Optical signals can be output or a nutrunner de-energized via a separate power supply.

#### Inputs

Sensor 1: Active torque sensor with or without speed- or angle recording, and with two ranges.

Sensor 2: Active torque sensor without speed- or angle recording, force sensor or stroke sensor.

If single-range transducers are used, both sensors can be connected simultaneously to the measurement module.

Custom software or non-standard functions can be provided upon request.

## Technical Data ValueMasterbase

Supply voltage:	100 - 240 V / 50 - 60 Hz with plug-in power supply unit
Sensor power supply (per channel):	12 V DC / 200 mA
<b>Analog input:</b>	0 to $\pm 5$ V or 0 to $\pm 10$ V
Range:	0 to $\pm 6,25$ V or 0 bis $\pm 12,5$ V
Input resistance:	1 M $\Omega$
Accuracy:	0,2 %
Nonlinearity:	0,1 %
Threshold frequency (3 dB):	35 kHz (with filter: 1 kHz)
<b>Input signal speed or angle of rotation:</b>	2-channel sinusoidal, cosine, TTL or open collector
Frequency range:	0 - 25 kHz
AD converter resolution:	11 bit + 1 sign bit
Digital input:	remote start
Digital outputs (optocouplers):	IO, NIO, motor start, ready max. 24 V / 150 mA
Analog output for direction of rotation and speed setpoint of the drive:	$\pm 10$ V 11 bit + 1 sign bit
Network connection:	Ethernet 100 MBit/s
Dimensions:	190 x 112 x 51 mm
Weight:	approximately 900 g

### Order code:

#### ValueMasterBase

(crossover cable, plug-in power supply unit and software are all supplied.)

### Supplied fittings:

cable  
torque sensors  
force sensors

A selection of the numerous ValueMasterbase functions and plots are visualized on the following pages. Please follow the link to [website/analyzers/ValueMaster\\_base](http://website/analyzers/ValueMaster_base) for a complete user manual.





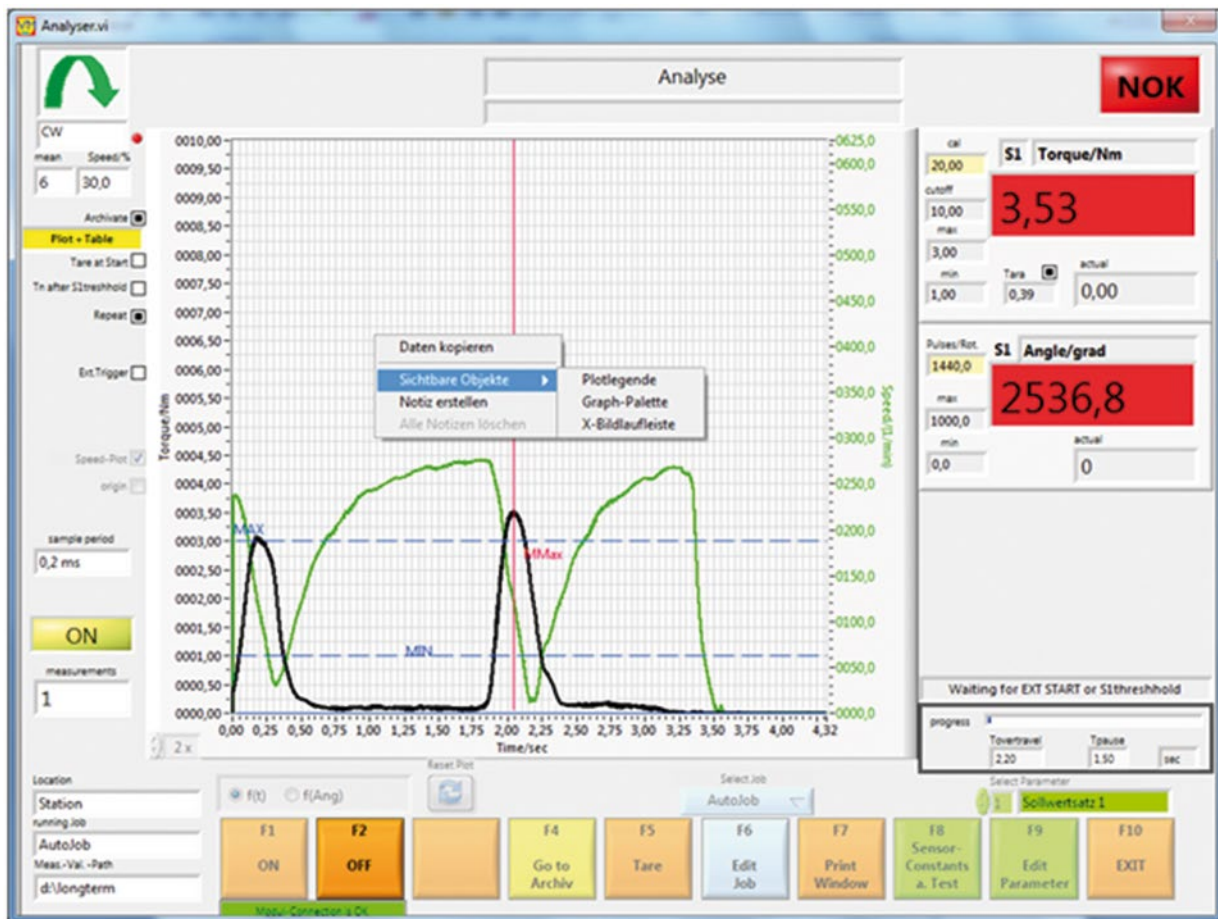

▲ The standard test is performed with the setpoint record. It can be started and stopped any number of times with “F1 ON” and “F2 OFF”, respectively.

▼ Analysis screen for up to 24 archived torque plots for the “Analysis” function with plot legend.

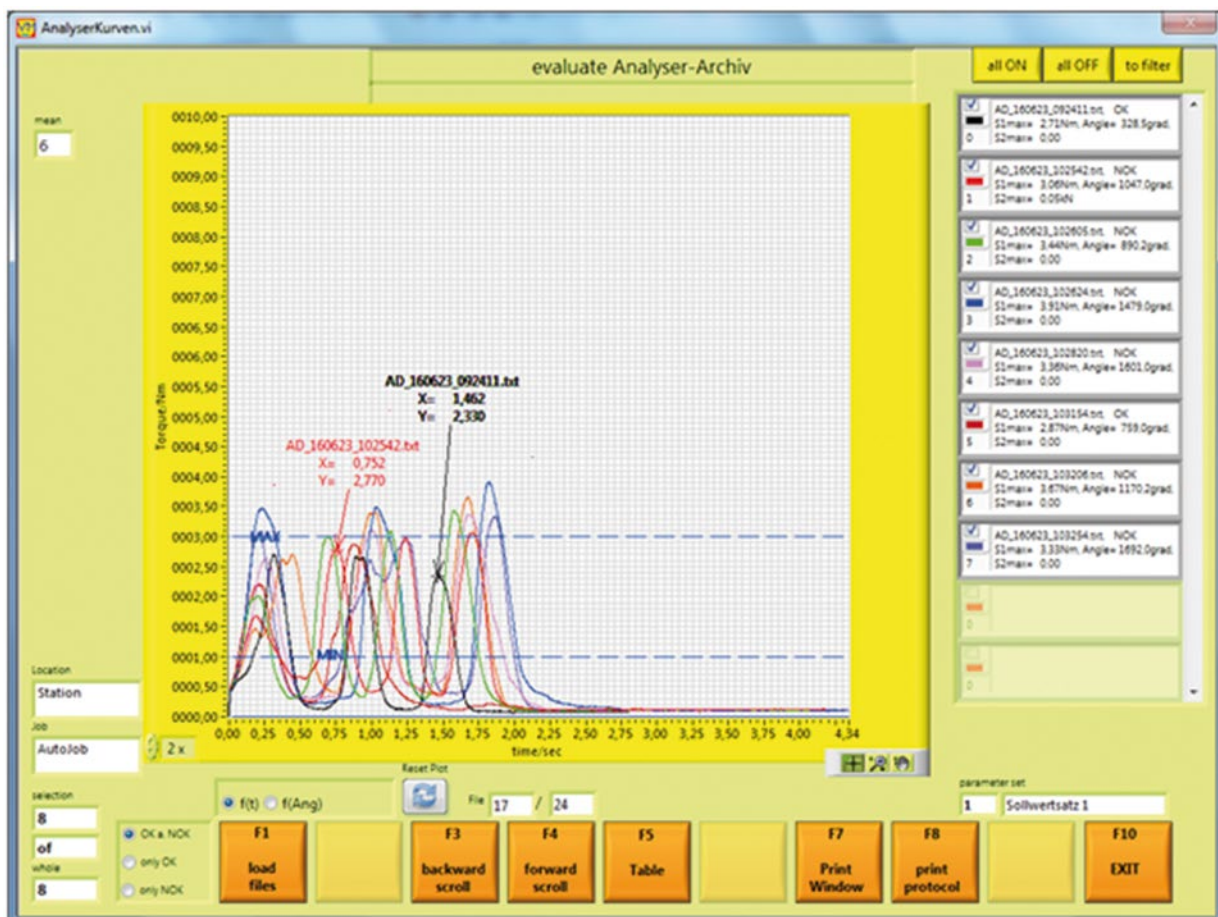

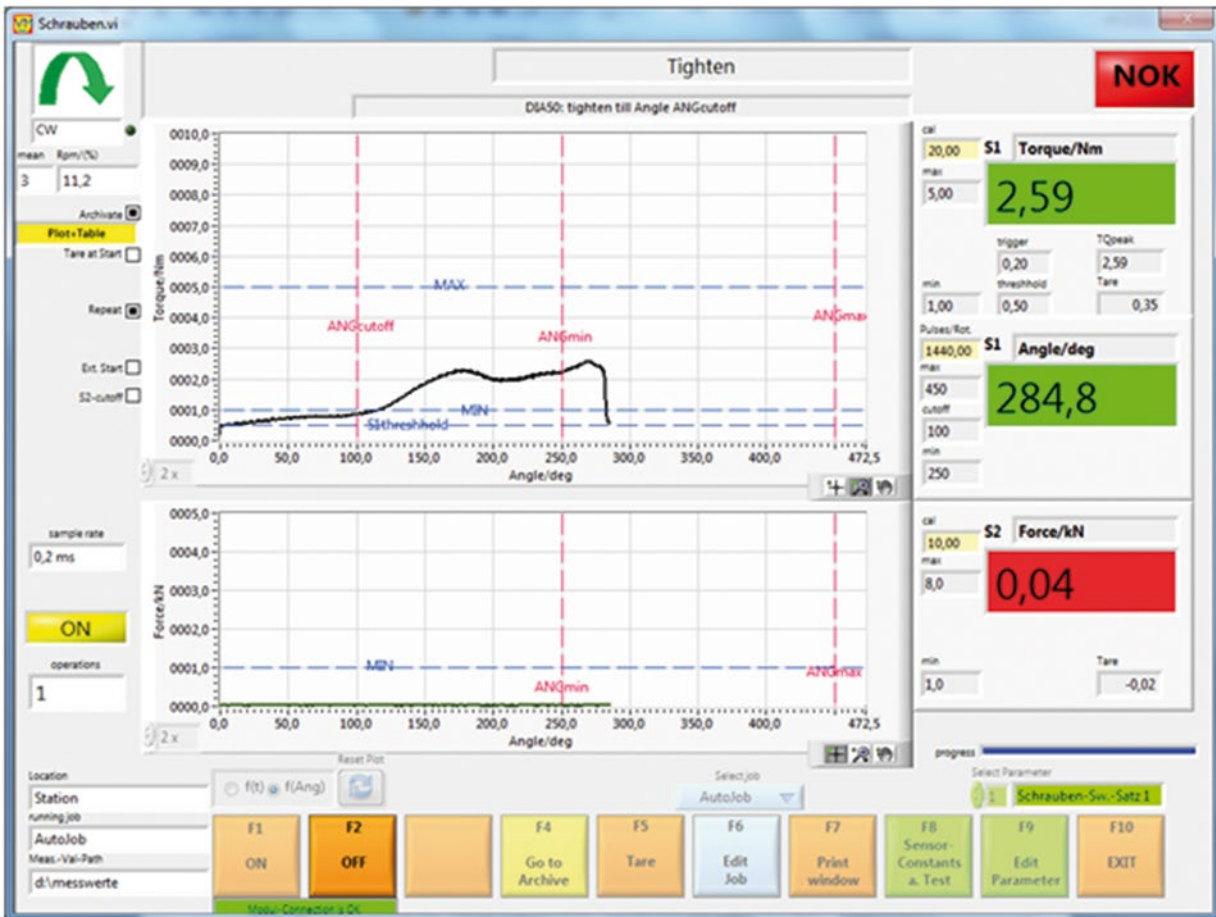

▲ Screwing function after an NIO screwing (pretension force not reached).

▼ Setpoints entry screen for DIA20.

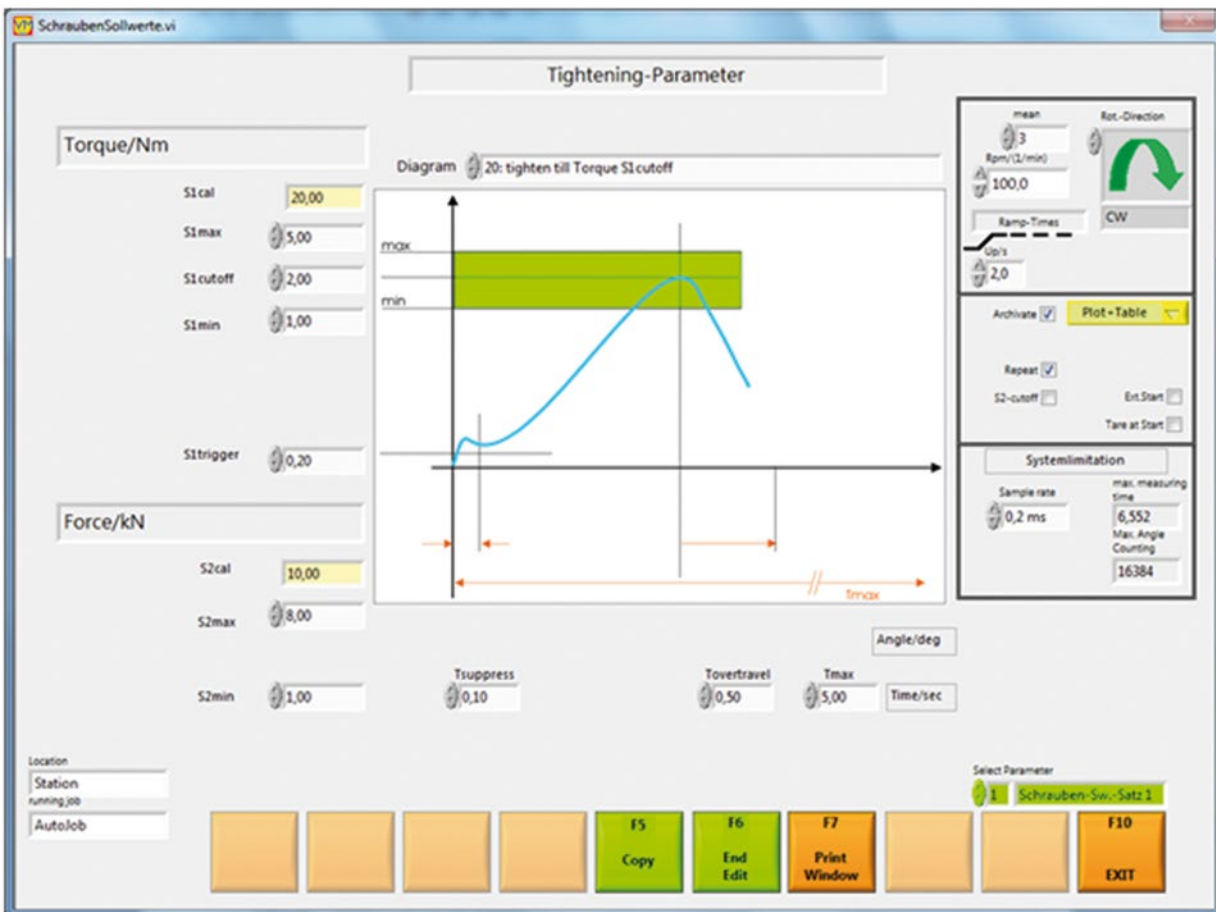

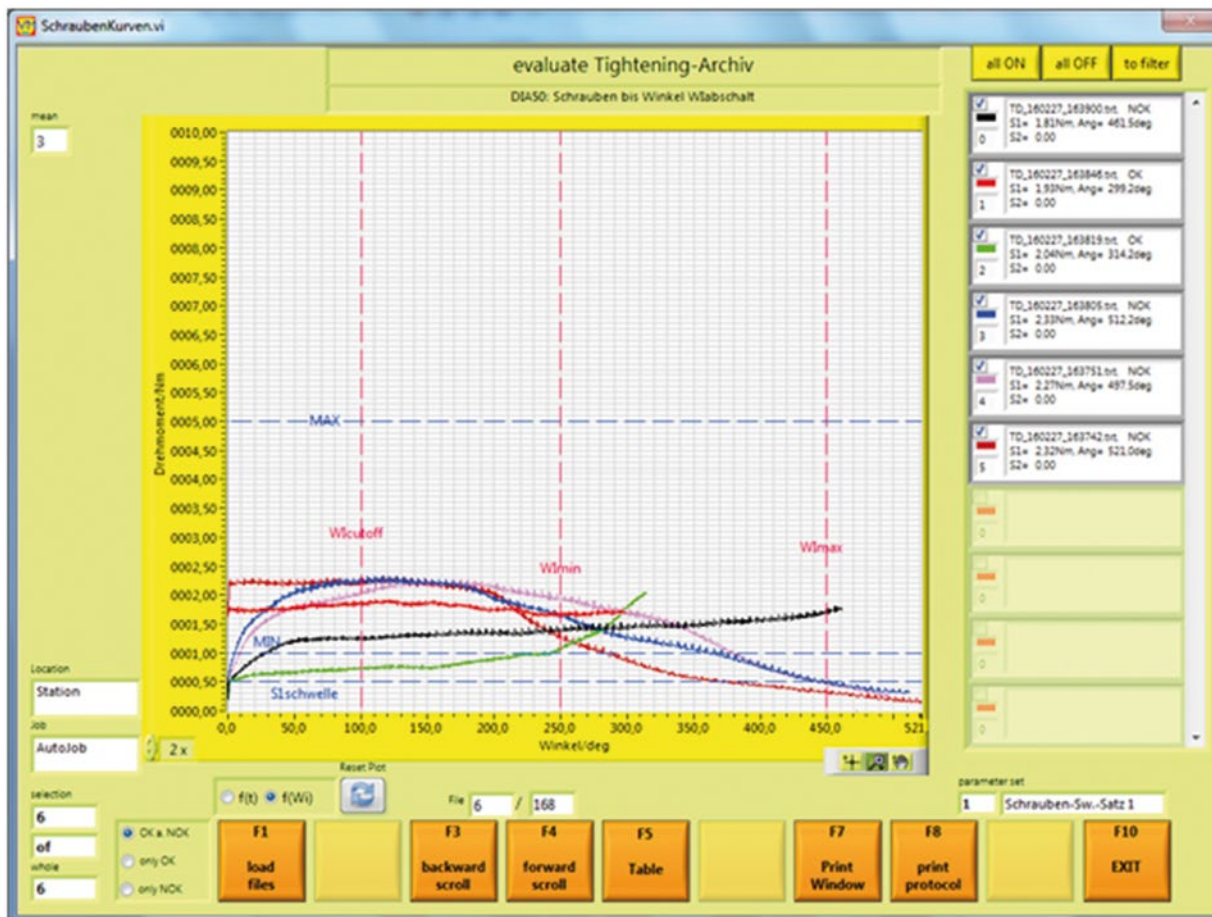

▲ Analysis screen for 6 archived torque plots for the “Screwing” function with plot legend.

▼ Power measurement with torque, power and speed.



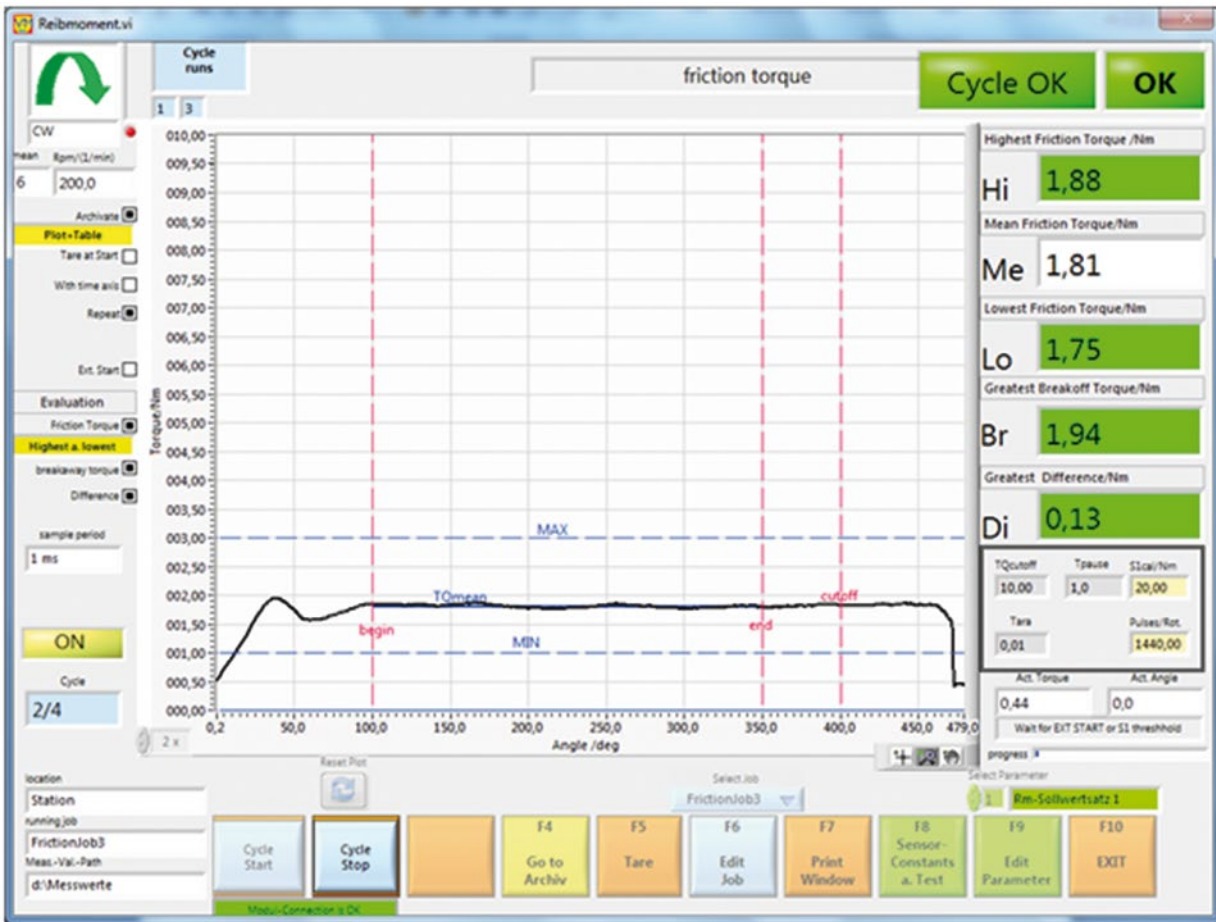

▲ “Friction torque measurement” function with evaluation angle. Programmable cyclical operation. Each program step (maximum 4) is performed like a standard test. Any number of tests can be run with the setpoint record.

▼ The type of evaluation can be selected when entering the setpoint for friction torque.

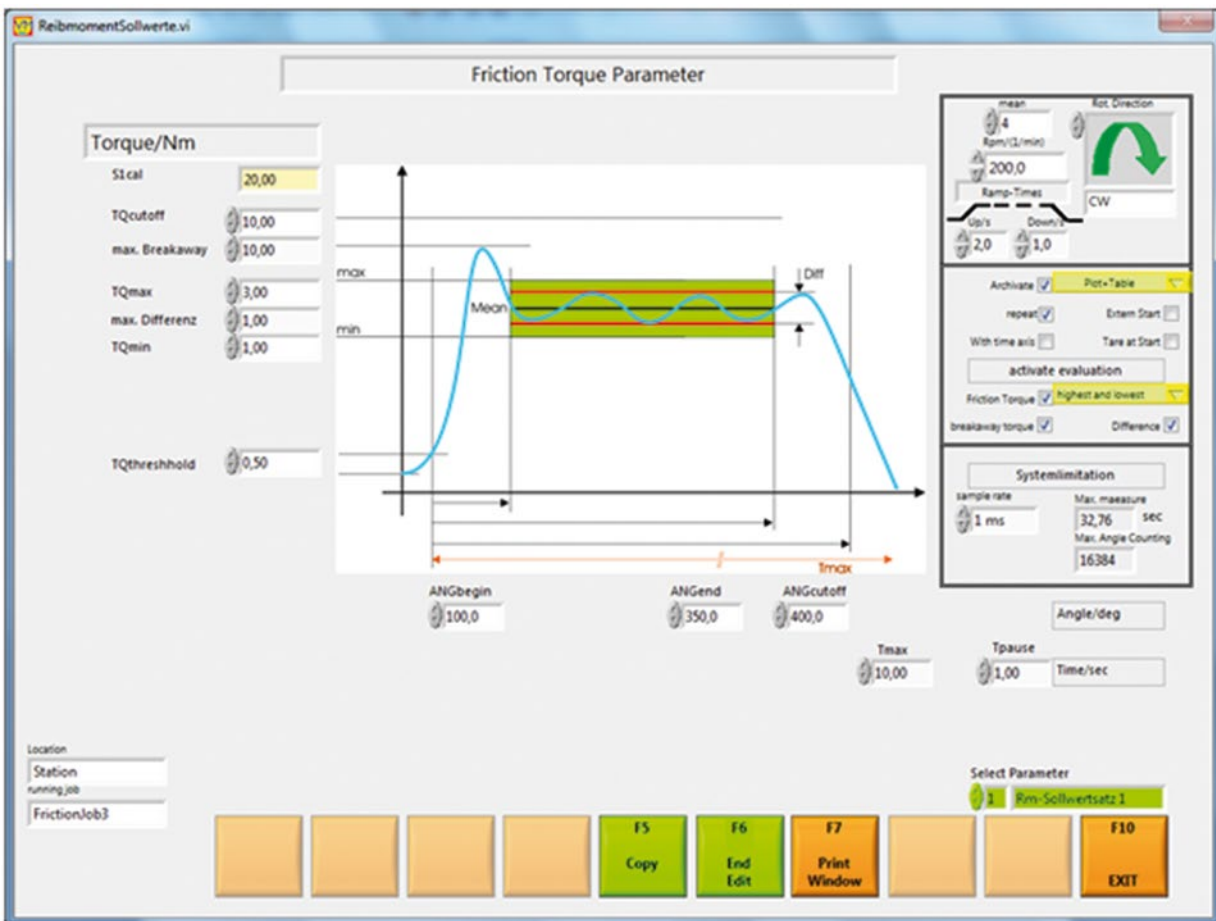

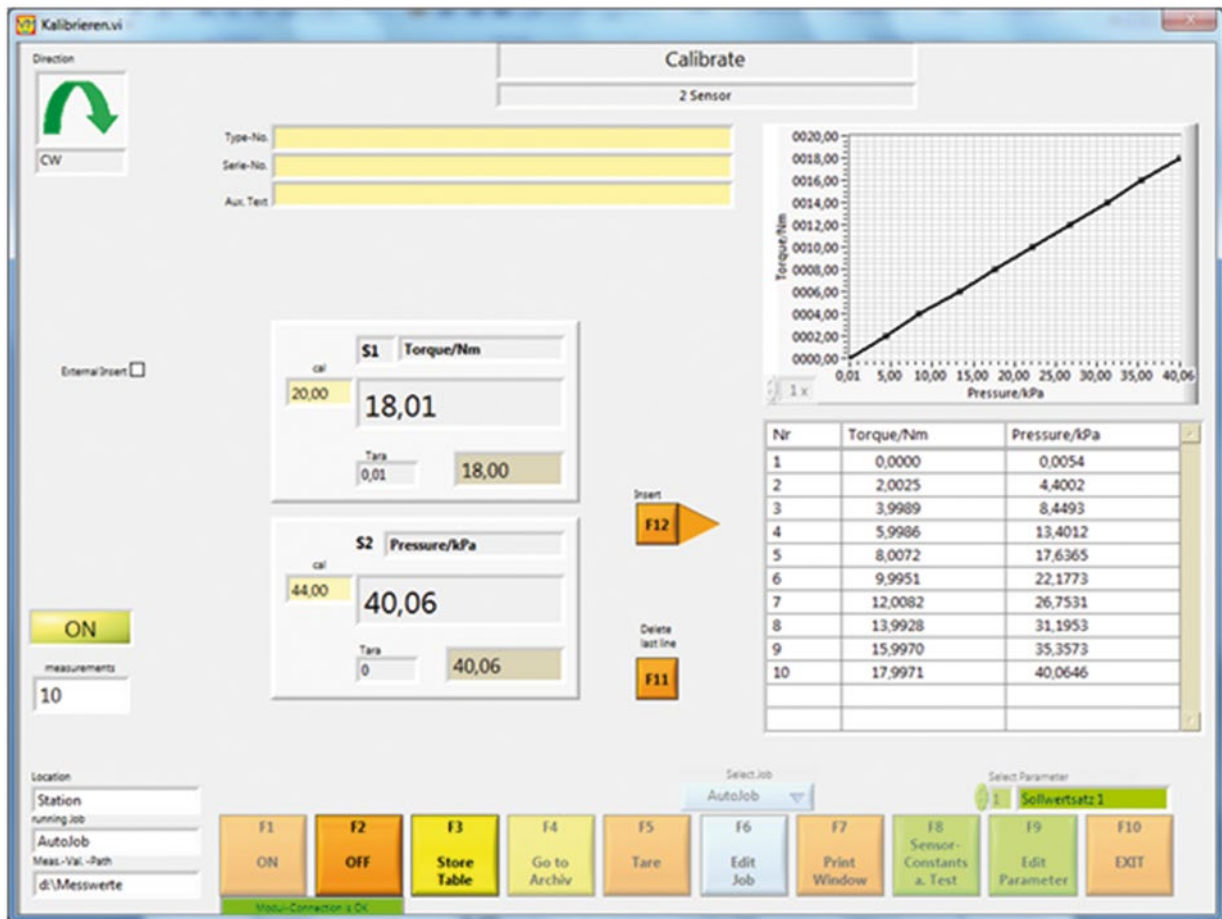

- ▲ Calibrate function screen: Control variable S2 (pressure), measured variable S1 (torque). Torque-pressure tables for hydraulic- and pneumatic screwdrivers can be created with this function.
- ▼ The inputs from sensor 1 and sensor 2 and the angle sensor are plotted as with an oscilloscope. The format and number of graphics windows are determined by the sensor constants selected.

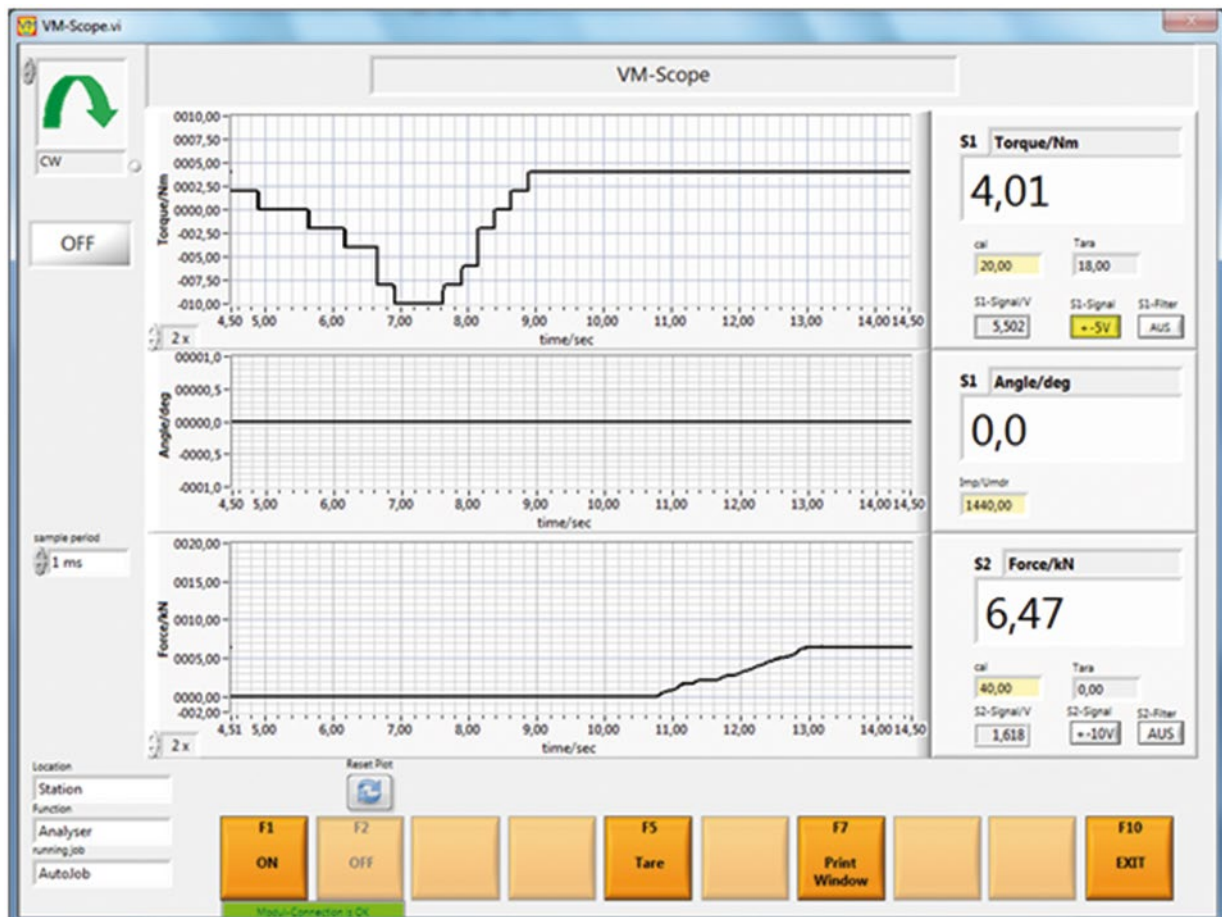

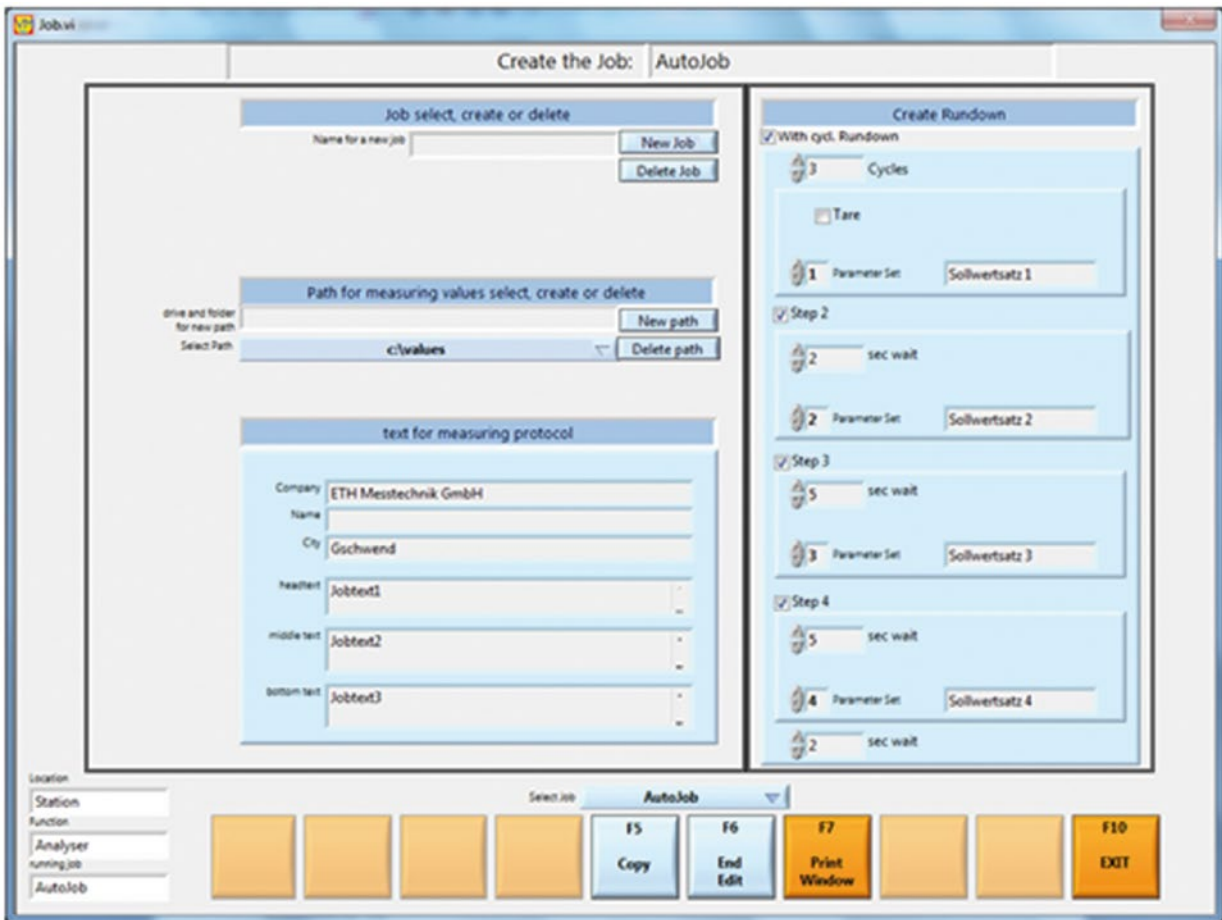

- ▲ The job subfunction can be called in every function (Analysis, Screwing, Friction torque, Power, Calibration). A job can be setup for different tests at different locations in Job administration.

▼ Test hardware screen.

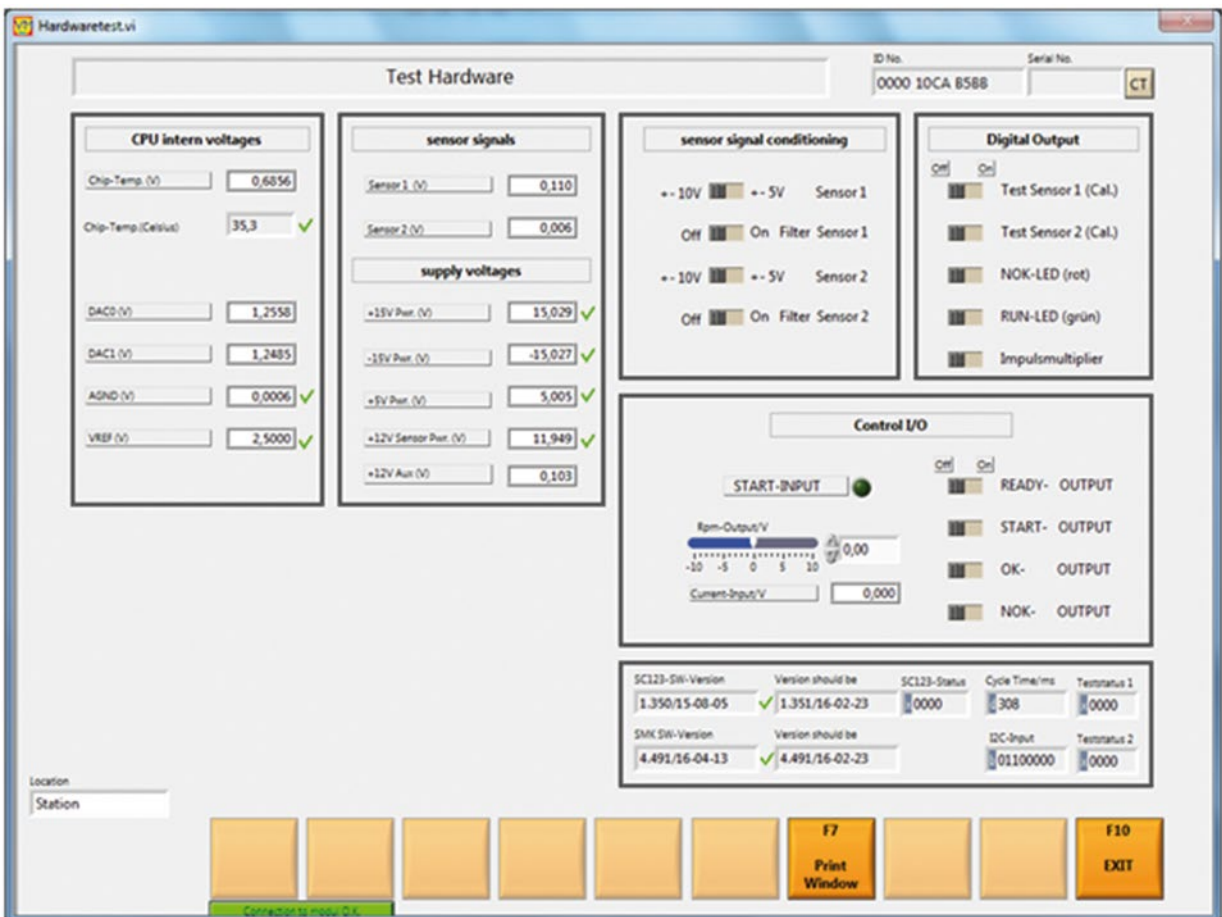

## Datasheet

### Multipurpose Torque Meter

# GMV2

for general stationary or mobile use

#### Typical Applications:

- Tool testing
- Production supervising
- Documentation compliant with DIN EN ISO 9001
- Quality Assurance
- Test bench evaluation



#### Standard for active torque sensors

- Measurement of torque, speed and power
- Measurement modes: tracking, peak (clockwise/ counterclockwise), torque wrench test
- Menu-driven operation and adjustment
- Storage for 1000 measurements
- 50 programmable parameter sets
- Power supply 110-240 V
- RS 232C port, max. 19200 baud
- Software 'GMV2-PC-Trans'
- EMC-proof housin
- Multilingual

The GMV2 is a microprocessor-based measurement and control unit for various torque-based applications. Measurement values for torque, speed and power (and optional angle) that are scanned with appropriate torque sensors in screwing applications and in test benches in labs can be displayed, their compliance with pre-set limits evaluated, and stored. The device is operated in simple steps via a self-explanatory menu. Using a torque transducer with integrated recognition chip, the sensor data will be transmitted automatically into the parameter set by connecting the transducer to GMV2.

#### Options

- Angle measurement
- External control of storing, deleting and printing
- External selection of parameter sets
- Screwdriver control
- Passive input for sensors 0.5–4 mV/V
- Digital input for DRFD sensors
- Analog output for torque signal
- Battery operation for 8 hours

Access to the device settings can be restricted by using passwords in three levels.

Measurement data will be stored in the device in combination with date and time and they can be printed out on an external printer or exported for further processing.

Option: a pulsed tool can be operated about a floating output.

Option: integrated power unit for operating a power screwdriver 230 V max. 16 A.

## Technical Specifications

<b>Power Supply</b>	
Mains voltage::	100 V - 240 V / 50 Hz - 60 Hz via IEC (power) connector
Operating mode:	simultaneous mains and charging mode with bat- tery option
<b>Sensor power supply</b>	
for torque transducer	12 V DC / 200 mA
Active input:	programmable
Input sensitivity:	from $\pm 1,25$ V to $\pm 10$ V
Input resistance:	1 M $\Omega$
Zero adjustment range:	approx. $\pm 7$ % of full scale
<b>Conversion</b>	
Pulse rise time:	10 % - 90 %: 0,25 ms
Max. measurement frequency:	3 KHz sine-wave pulse
<b>Accuracy</b>	
Tracking mode:	$\leq 0,1$ % $\pm 2$ digit
Peak mode:	$\leq 0,3$ % $\pm 2$ digit
Torque-wrench mode:	$\leq 0,3$ % $\pm 2$ digit
Speed	
at $n \leq 10000$ min-1:	$\leq \pm 2$ digit
at $n \leq 20000$ min-1:	$\leq \pm 3$ digit
Angle of rotation:	$\pm 0,25^\circ$ to $100^\circ$ then $1^\circ$
Zero error:	$\leq 0,05$ %
Storage:	50 measurement programs 1000 measurement values
Display:	Graphics-LCD with 240 x 64 pixels
Data output:	RS 232 serial port 9 pin connector (DEE) 1200 – 19200 baud
Ambient temperature:	0 - $45^\circ$ C
Humidity:	< 75 %
Protection:	IP 40 as per DIN 40050
Dimensions: (without handle)	257 x 118 x 266 mm (W x H x D)
Weight:	approx. 3.8 kg with battery approx. 5 kg
<b>Colors</b>	
Housing:	RAL 9006 (white aluminum)
Frame:	RAL 7016 (anthracite gray)
Design strips:	RAL 3002 (carmine red)

### Option – Battery operation

Supply voltage:	battery 2 x 6 V / 4 Ah
Operating time for continuous operation:	approx. 8 h (with sensor)

### Option – Digital input

for sensor type DRFDxx

### Option – Passive input

Input sensitivity:	programmable from $\pm 0.5$ mV/V to $\pm 4$ V/V
Adjustment range:	approx. $\pm 7$ % of full scale
Sensor passive power supply 4-wire power supply	7 V DC 350 - 1000 $\Omega$

### Option – Angle measurement

Input signals:	2 channels 360 pulses / revolution with approx. $90^\circ$ phase shift
Resolution:	$0,25^\circ$
Counting range:	$\pm 6000^\circ$

### Option – Barcode scanner

Manual scanner:	80 mm
Code:	39

### Option – Control input and outputs

2 relay outputs:	IO / NIO
U max :	25 V AC / 30 V DC
I max:	1 A
Switching delay:	$\leq 1,6$ ms
2 optocoupler outputs:	shutdown / spare
U max :	30 V DC
I max :	300 mA
Saturation voltage:	< 2 V (100 mA) < 1,5 V (50 mA) < 1 V (2 mA)
Switching delay::	$\leq 0,2$ ms
Shutdown response time:	$\leq 0,5$ ms
2 optocoupler inputs	Store / print / delete
Signal level ON:	4 V ....30 V / 3 mA
Signal level OFF:	< 1,5 V

### Option – Voltage output

Voltage output:	$0 \pm 5$ V $R_i = < 100 \Omega$ alternative $0 \pm 10$ V $R_i = < 100 \Omega$
Short-circuit current:	10 mA



## Features

- Measurement of torque, speed and power
- Tracking mode with adjustable filter for torque and speed power measurement from 1 mW up to 20,000 kW continuous measurement output or periodic storage of values
- Peak mode in clockwise or counter-clockwise direction with
  - display status of peak measurement
  - adjustable correction factor for pulsed tools
  - adjustable moving average for torque
  - averaging surveillance function
- Torque-wrench measurement with display of peak value at yielding point
- 50 programmable measurement programs
- Storage for 1000 measurement values
- Adjustable erasing time and start-up suppression times
- RS232C port up to 19200 baud
- EMC-proof housing
- Mains operation 110 to 240 V / 50 - 60 Hz
- Data transfer to MS-Excel<sup>®</sup> with data-transfer software GMV2-PC-Trans  
Serial cable supplied with device
- Automatic scanning of transducer data and checking the parameter set for transducers with integrated chip
- Self-explanatory menu structure in many languages
- Protection of settings by passwords in three levels

## Options

- Angle measurement
- Battery operation for 8 hours, integral battery charger and power supply
- Passive input for sensors
- Digital input for sensors
- Controlling electric screw drivers with separate power unit (ETH-Accessories `LTE2' )
- Signal input for dual-range torque transducer (ETH-Sensor Type DRDL)
- External control of storing, erasing and printing
- Analog output for torque signal
- External selection of parameter sets
- Input with barcode scanner
- **Special options on request!**

## Ordering Code System

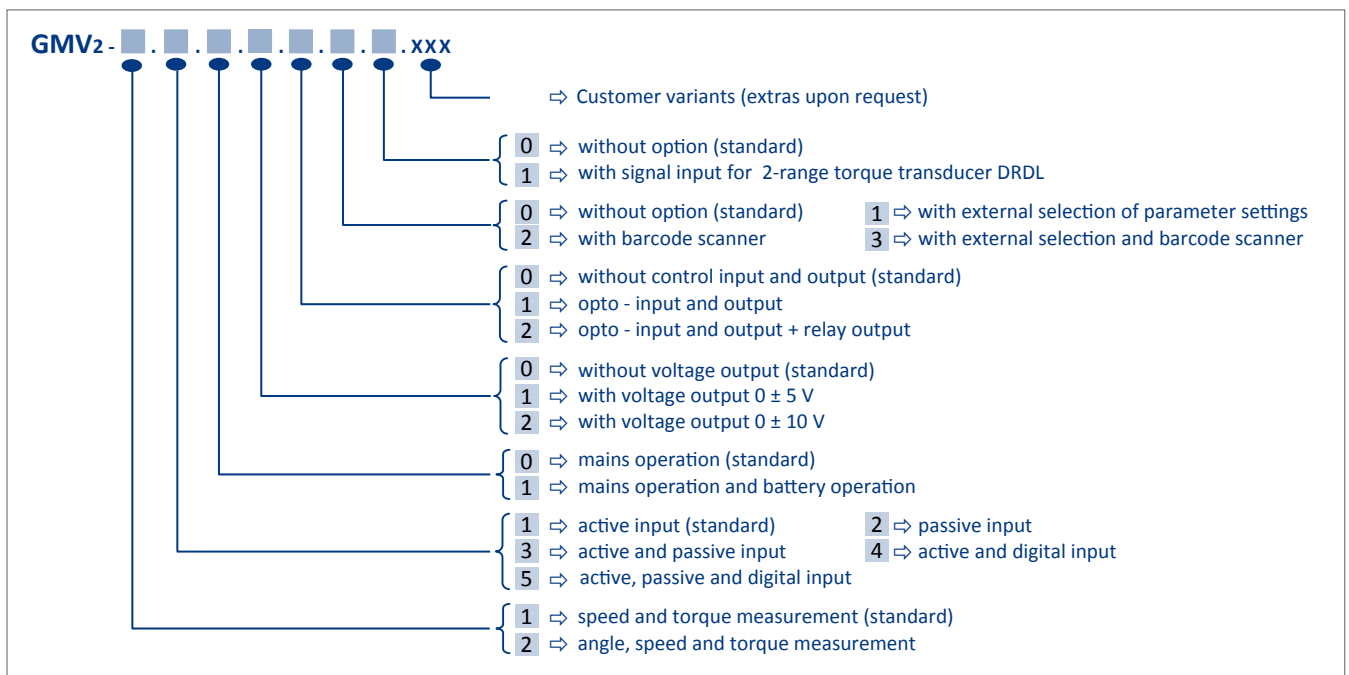

PAR	DS	SP	Wert / Einheit	Wert GW min	Wert GW max	Winkel / Grad	Wi.-GW min	Wi.-GW max	Uhrzeit	Datum	DS-Kennz.	Werker-Nr.	PAR-Bezeichnung
3	1	1	54,5 Nm	54	61	28	22,5	30,25	14:52	26.06.17	LAGER 1	521	MOTOR 623
3	1	2	55,1 Nm	54	61	24,75	22,5	30,25	14:52	26.06.17	LAGER 1	521	MOTOR 623
3	1	3	55,5 Nm	54	61	35,5	22,5	30,25	14:52	26.06.17	LAGER 1	521	MOTOR 623
3	1	4	54,5 Nm	54	61	27,5	22,5	30,25	14:52	26.06.17	LAGER 1	521	MOTOR 623
3	1	5	55 Nm	54	61	24	22,5	30,25	14:53	26.06.17	LAGER 1	521	MOTOR 623
3	1	6	53,4 Nm	54	61	22,75	22,5	30,25	14:53	26.06.17	LAGER 1	521	MOTOR 623
3	2	1	54,1 Nm	54	61	33,5	22,5	30,25	14:53	26.06.17	LAGER 2	521	MOTOR 623
3	2	2	54,4 Nm	54	61	24,75	22,5	30,25	14:53	26.06.17	LAGER 2	521	MOTOR 623
3	2	3	55,5 Nm	54	61	24,25	22,5	30,25	14:54	26.06.17	LAGER 2	521	MOTOR 623
3	2	4	56,3 Nm	54	61	30	22,5	30,25	14:54	26.06.17	LAGER 2	521	MOTOR 623
3	2	5	55,1 Nm	54	61	25,75	22,5	30,25	14:54	26.06.17	LAGER 2	521	MOTOR 623
3	2	6	55,9 Nm	54	61	23	22,5	30,25	14:54	26.06.17	LAGER 2	521	MOTOR 623
3	3	1	52,1 Nm	54	61	28	22,5	30,25	14:55	26.06.17	LAGER 3	521	MOTOR 623
3	3	2	54,1 Nm	54	61	23	22,5	30,25	14:55	26.06.17	LAGER 3	521	MOTOR 623
3	3	3	54,1 Nm	54	61	23,5	22,5	30,25	14:55	26.06.17	LAGER 3	521	MOTOR 623
3	3	4	54,4 Nm	54	61	29,75	22,5	30,25	14:55	26.06.17	LAGER 3	521	MOTOR 623
3	3	5	54,1 Nm	54	61	25	22,5	30,25	14:55	26.06.17	LAGER 3	521	MOTOR 623
3	3	6	55,8 Nm	54	61	27,5	22,5	30,25	14:56	26.06.17	LAGER 3	521	MOTOR 623

Prüfbedingungen					
Temperatur	22,5 °C	Rel. Luftfeuchte	10 (<= 90%)		
Sensor		Messgerät			
Hersteller:	ETH	Hersteller:	ETH		
Typ	DRT x	Typ	GMV2 (aktiv)		
Serien Nr.:	654321	Serien Nr.:	543210		
nächste Prüfung	11. Jun. 2018	nächste Prüfung	11. Jun. 2018		
Messunsicherheit mit ErweiterungsfaktorK=			< ±1%		
Drehmomentwerkzeug					
Hersteller:	XY	Typ	2		
Artikelbezeichnung:	MD-Schlüssel	Klasse:	A		
Serien Nr.:	123456	max. Drehmoment:	100,0		
Inventarnummer:	123456	Einheit:	Nm		
zulässige Toleranz:	<= ±4%	Skaleneinteilung:	≤ 5%		
Prüfblauf					
Vorbereitung:	-GMV2: Knickschlüsselmessung -5° mit max. Drehmoment auslösen				
Prüfung:	1.) 5 x <= 20,00 Nm 2.) 5 x ca. 60,00 Nm 3.) 5 x 100,00 Nm				
Ergebnisse					
1.Einstellwert	20,00Nm	2.Einstellwert	60,00Nm	3.Einstellwert	100,00Nm
Kalibrierwert	Fehler	Kalibrierwert	Fehler	Kalibrierwert	Fehler
20,00 Nm	0,00 %	59,80 Nm	0,33 %	101,50 Nm	-1,48 %
20,50 Nm	-2,44 %	60,10 Nm	-0,17 %	101,00 Nm	-0,99 %
19,50 Nm	2,56 %	60,50 Nm	-0,83 %	100,30 Nm	-0,30 %
20,30 Nm	-1,48 %	60,00 Nm	0,00 %	101,00 Nm	-0,99 %
19,80 Nm	1,01 %	59,40 Nm	1,01 %	99,20 Nm	0,81 %
maximaler Fehler:		2,56 %		Kalibrierung: IO	

Bestätigung der Kalibrierung nach ISO 6789 Datum, Name, Unterschrift

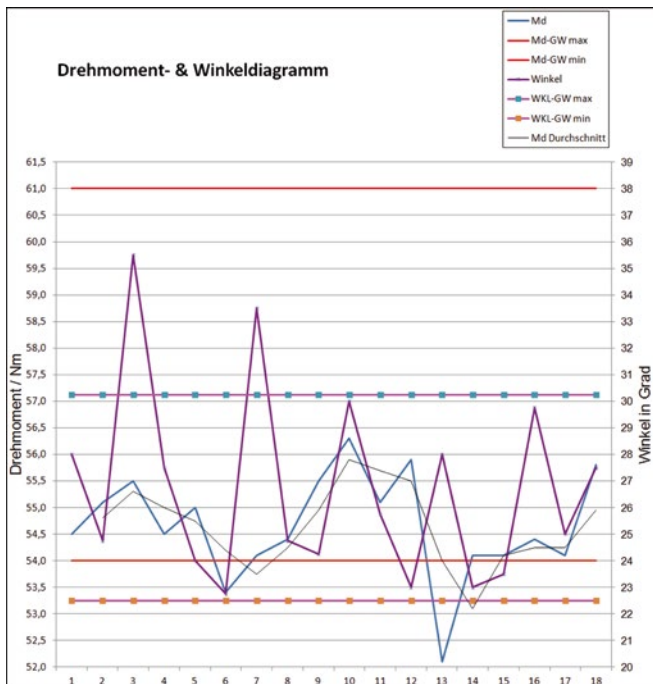

System requirements: up to Win 10, Office 95 - 2016

Überprüfung		vom: 26.06.17 bis: 26.06.17	
Werkzeug / (Werkstück)			
Bezeichnung: VK-623	Messprog. Name: MOTOR 623		
Typ: RS25	Datensatz-Kennz.: LAGER 1		
Hersteller: Hudelemaier	Werknummer: 521		
Serien Nr.: 2564482	zuletzt geprüft: -----		
Inventarnummer: 3684423	Kalibrierintervall (Mon.): -----		
Einsatzort: Ulm	nächste Prüfung: -----		
Messmittel			
Sensor		Messgerät:	
Bezeichnung: Drehmomentsensor 1/2"	Bezeichnung: GMV2		
Typ: DRFN-100-w	Typ: GMV2-2.1.1.0.000		
Hersteller: ETH	Hersteller: ETH		
Toleranz: 0,15%	Toleranz: 0,30%		
Serien Nr.: 625735845	Serien Nr.: 625735762		
Inventarnummer: 75-5567	Inventarnummer: 75-5568		
Kalibrierung gültig bis: 01.08.18	Kalibrierung gültig bis: 31.08.19		
Par.-Nr.: 3	von DS: 1	bis DS: 3	Datensatzlänge: 6
Anzahl Datensätze: 3		Anzahl n: 18	
Drehmoment		Winkel	
Mittelwert Xquer:	54,661 Nm	Mittelwert Xquer:	26,69 Grad
Bereich R:	4,200 Nm	Bereich R:	12,75 Grad
Max:	56,300 Nm	Max:	35,50 Grad
Min:	52,100 Nm	Min:	22,75 Grad
Standardabw. (s):	0,972 Nm	Standardabw. (s):	3,55 Grad
±3 s :	2,917 Nm	±3 s :	10,64 Grad
Sigma (s):	1,001 Nm	Sigma (s):	3,65 Grad
±3 s / % :	3,002 / ± 5,49%	±3 s / % :	10,95 / ± 41,02%
Soll-Drehmoment:		Soll-Winkel:	
Grenzwert max:	61,000 Nm	Grenzwert max:	30,25 Grad
Grenzwert min:	54,000 Nm	Grenzwert min:	22,50 Grad
Anzahl > GWmax / % :	0 0,00%	Anzahl > GWmax / % :	2 11,11%
Anzahl < GWmin / % :	2 11,11%	Anzahl < GWmin / % :	0 0,00%
Cm/Cp:	1,2	Cm/Cp:	0,4
Cmk/Cpk:	0,2	Cmk/Cpk:	0,3
Gesamt			
Anzahl IO / % :	14 77,78%	Cpk gefordert:	1,0
Anzahl NIO / % :	4 22,22%	Status:	NIO

Prüfprotokoll Drehmomentschlüssel			
Sensor			
Fabrikat:	ETH	Serien Nr.:	7010xxxx
Typ:	DRT x	Inventarnummer:	0815
Geprüft Datum:	11. Jun. 17	Toleranz:	≤ 0,15 %
Prüfintervall:	1 Jahr	nächste Prüfung:	11. Jun. 18
Messgerät			
Fabrikat:	ETH	Serien Nr.:	7010xxxy
Typ:	GMV2 (aktiv)	Inventarnummer:	0816
Geprüft Datum:	24. Jan. 17	Toleranz:	≤ 0,3 % ± 2 Digit
Prüfintervall:	1 Jahr	nächste Prüfung:	24. Jan. 18
Drehmomentschlüssel			
Hersteller:	Hauruck		
Artikelbezeichnung:	Drehmomentschlüssel		
Serien Nr.:	4711		
Inventarnummer:	123456		
Drehmomentbereich:	20 - 100 Nm		
Skaleneinteilung:	5 Nm		
Toleranz:	3%		
Messwerte		Ergebnisse	
	75,00	Mittelwert:	75,04
1. Prüfung	75,20	Abweichung:	0,05%
2. Prüfung	75,80	+/- 3 Sigma:	1,55
3. Prüfung	74,80		
4. Prüfung	74,40		
5. Prüfung	75,00		

## Datasheet

Microprocessor controlled evaluation

# GMV2-K

ideal for mobile use in the outdoor area:  
Building sites, Off-shore, Shipyards, Mining, ...

**robust ✓**  
**impact resistant ✓**  
**waterproof ✓**

Application range:

- Tool testing
- production monitoring
- Documentation according to DIN EN ISO 9001
- quality assurance

Standard equipment for active sensors

- Detection of torque, angle and speed
- Measurement types: idler, peak (forward / reverse), wrenches
- USB interface
- Integrated performance
- Menu-driven operation and adjustment
- RS 232C interface to 19200 baud
- 1000 measured values storable

The GMV2-K is a microprocessor-controlled supply and display unit for various applications in torque-measurement. In screwing sector with appropriate sensors detected measurement values for torque and angle, speed and power can be displayed, evaluated conforming to pre-set limits and stored. The handling using a self-explanatory menu is carried out in simple steps. Using a torque transducer with integrated recognition chip the sensor data will be transmitted automatically into the parameter set by connecting the transducer to GMV2. For better distinction the parameter-sets and data-sets can be



- 50 parameter sets can be programmed
- Software ,GMV2-PC-Trans‘
- Networking (Option: 4 hours battery mode)
- tightening controller
- AC adapter / charger
- Output to Digimatic mini-processor printer
- multilingual

named with text. The access to the general settings can be limited by using passwords in three levels. The measured values will be internal stored in combination with date and time and they can be printed out by an external printer or transmitted to an existing EDP.

Option: A hydraulic screwdriver can be controlled via a potential-free output.

Option: Integrated power section for the operation of an electric screwdriver 230 V max. 16 A.

## Technical Specifications

<b>Supply voltage</b>	
Power supply:	100 V - 240V/50 Hz - 60 Hz über Kaltgerätestecker
Operating mode:	Simultaneous network and charging with battery
<b>Sensor supply</b>	
for torque transducers	12 V DC / 200 mA
<b>INPUT activ:</b> free programmable	
Input sensitivity:	from $\pm 1,25$ V to $\pm 10$ V
Input resistance:	1 M $\Omega$
Zeropoint-tare:	approx. $\pm 7$ % of full scale
<b>Transformation</b>	
Pulse rise rate:	10 % - 90 %: 0,25 ms
Max. measuring frequency	3 KHz Sinuspulse
<b>Accuracy</b>	
Tracking:	$\leq 0,1$ % $\pm 2$ Digit
Peak measurement:	$\leq 0,3$ % $\pm 2$ Digit
Torque Wrench measurement:	$\leq 0,3$ % $\pm 2$ Digit
<b>Speed</b>	
at $n \leq 10.000$ min-1:	$\leq \pm 2$ Digit
at $n \leq 20.000$ min-1:	$\leq \pm 3$ Digit
Angle:	$\pm 0,25^\circ$ to $100^\circ$ then $1^\circ$
Zero error:	$\leq 0,05$ %
Memory:	50 measuring programs 1000 measured values
Display:	Grafic-LCD with 240 x 64 pixels
Data output:	RS 232 interface 9 pol. connector (DEE) 1200 – 19.200 Baud USB 1.1/2.0
Comp.temperature range:	0 - 45°C
Humidity:	< 75 % (constantly)
Protection:	Open suitcase IP54 Closed Case IP65 DIN 40050
Dimensions:	330x234x152 mm (BxHxT)
Weight:	approx. 5,5 kg with Battery
<b>Color</b>	
Case:	yellow
Front panel:	grey

<b>Angle Option</b>	
Input signals:	2 tracks 360 pulses / revolution with Approx. 90 degree phase offset
Resolution:	0,25 degrees
Counting range:	$\pm 6000$ degrees

<b>Battery Option</b>	
Power supply:	Battery 2 x 6 V / 3,4 Ah
Operating time:	with continuous operation approx. 4 h (with trans- ducer)

<b>Option - Control output hydraulic screwdriver</b>	
Relay output:	Shut-off screwdriver
U max :	25 V AC / 30 V DC
I max:	1 A
Switching delay:	$\leq 1,6$ ms

<b>Option - Control electric screwdriver</b>	
Voltage output:	100 - 240 V AC (same as supply voltage GMV2-K)
Switching current:	max. 16 A
Switching delay:	$\leq 0,2$ ms
Response time Switch-off:	$\leq 0,5$ ms

## Features

- 1000 measured value memory
- 50 freely adjustable measuring programs
- Self explanatory menu structure in several languages
- Protection of device settings by password in 3 levels
- Automatic transfer of transducer data and control the parameter set sensors with chip
- Detection of torque, speed and power
- With adjustable filter
  - for torque and speed
  - power measurement from 1 mW to 20.000 kW
  - Continuous measurement output or storage at intervals
- Peak value measurement in clockwise / anti-clockwise direction
  - with status display of the peak value measurement
  - adjustable correction factor for pulse tools
  - adjustable sliding averaging of the torque
  - sensor overload monitoring
- Adjustable deletion and start-times
- Knick key measurement with display of the peak value in the kinking point
- RS232C interface up to 19200 baud
- USB interface 1.1 / 2.0
- Waterproof housing
- Power supply 100 - 240 V

## Optional additional equipment

- Detection of rotation angles
- Screw control via integrated power section
- Battery operated for 4 hours, Charger / power supply installed
- Control output for hydraulic screwdrivers
- **Special options on request!**

## Ordering code system

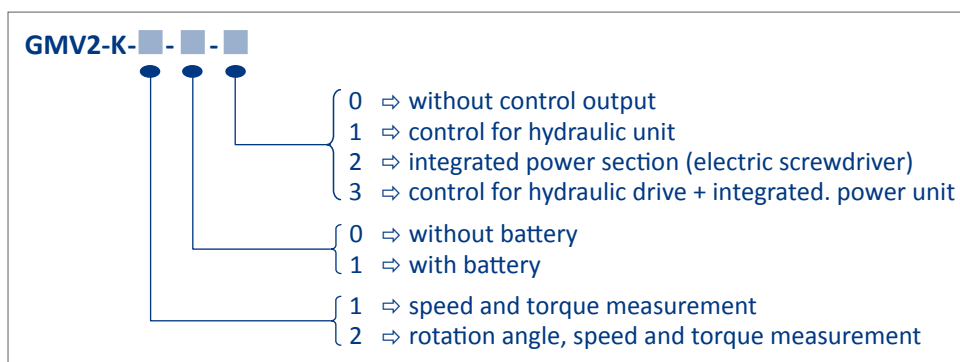

PAR	DS	SP	Wert / Einheit	Wert GW min	Wert GW max	Winkel / Grad	Wi.-GW min	Wi.-GW max	Uhrzeit	Datum	DS-Kennz.	Werker-Nr.	PAR-Bezeichnung
3	1	1	54,5 Nm	54	61	28	22,5	30,25	14:52	26.06.17	LAGER 1	521	MOTOR 623
3	1	2	55,1 Nm	54	61	24,75	22,5	30,25	14:52	26.06.17	LAGER 1	521	MOTOR 623
3	1	3	55,5 Nm	54	61	35,5	22,5	30,25	14:52	26.06.17	LAGER 1	521	MOTOR 623
3	1	4	54,5 Nm	54	61	27,5	22,5	30,25	14:52	26.06.17	LAGER 1	521	MOTOR 623
3	1	5	55 Nm	54	61	24	22,5	30,25	14:53	26.06.17	LAGER 1	521	MOTOR 623
3	1	6	53,4 Nm	54	61	22,75	22,5	30,25	14:53	26.06.17	LAGER 1	521	MOTOR 623
3	2	1	54,1 Nm	54	61	33,5	22,5	30,25	14:53	26.06.17	LAGER 2	521	MOTOR 623
3	2	2	54,4 Nm	54	61	24,75	22,5	30,25	14:53	26.06.17	LAGER 2	521	MOTOR 623
3	2	3	55,5 Nm	54	61	24,25	22,5	30,25	14:54	26.06.17	LAGER 2	521	MOTOR 623
3	2	4	56,3 Nm	54	61	30	22,5	30,25	14:54	26.06.17	LAGER 2	521	MOTOR 623
3	2	5	55,1 Nm	54	61	25,75	22,5	30,25	14:54	26.06.17	LAGER 2	521	MOTOR 623
3	2	6	55,9 Nm	54	61	23	22,5	30,25	14:54	26.06.17	LAGER 2	521	MOTOR 623
3	3	1	52,1 Nm	54	61	28	22,5	30,25	14:55	26.06.17	LAGER 3	521	MOTOR 623
3	3	2	54,1 Nm	54	61	23	22,5	30,25	14:55	26.06.17	LAGER 3	521	MOTOR 623
3	3	3	54,1 Nm	54	61	23,5	22,5	30,25	14:55	26.06.17	LAGER 3	521	MOTOR 623
3	3	4	54,4 Nm	54	61	29,75	22,5	30,25	14:55	26.06.17	LAGER 3	521	MOTOR 623
3	3	5	54,1 Nm	54	61	25	22,5	30,25	14:55	26.06.17	LAGER 3	521	MOTOR 623
3	3	6	55,8 Nm	54	61	27,5	22,5	30,25	14:56	26.06.17	LAGER 3	521	MOTOR 623

Prüfbedingungen					
Temperatur	22,5 °C				
Rel. Luftfeuchte	10 (<= 90%)				
Sensor					
Hersteller:	ETH				
Typ	DRT x				
Serien Nr.:	654321				
nächste Prüfung	11. Jun. 2018				
Messunsicherheit mit ErweiterungsfaktorK=	< ±1%				
Messgerät					
Hersteller:	ETH				
Typ	GMV2 (aktiv)				
Serien Nr.:	543210				
nächste Prüfung	11. Jun. 2018				
Messunsicherheit mit ErweiterungsfaktorK=	< ±1%				
Drehmomentwerkzeug					
Hersteller:	XY				
Artikelbezeichnung:	MD-Schlüssel				
Serien Nr.:	123456				
Inventarnummer:	123456				
zulässige Toleranz:	<= ±4%				
Typ	2				
Klasse:	A				
max. Drehmoment:	100,0				
Einheit:	Nm				
Skaleneinteilung:	≤ 5%				
Prüfblauf					
Vorbereitung:	-GMV2: Knickschlüsselmessung -5* mit max. Drehmoment auslösen				
Prüfung:	1.) 5 x <= 20,00 Nm 2.) 5 x ca. 60,00 Nm 3.) 5 x 100,00 Nm				
Ergebnisse					
1.Einstellwert	20,00Nm	2.Einstellwert	60,00Nm	3.Einstellwert	100,00Nm
Kalibrierwert	Fehler	Kalibrierwert	Fehler	Kalibrierwert	Fehler
20,00 Nm	0,00 %	59,80 Nm	0,33 %	101,50 Nm	-1,48 %
20,50 Nm	-2,44 %	60,10 Nm	-0,17 %	101,00 Nm	-0,99 %
19,50 Nm	2,56 %	60,50 Nm	-0,83 %	100,30 Nm	-0,30 %
20,30 Nm	-1,48 %	60,00 Nm	0,00 %	101,00 Nm	-0,99 %
19,80 Nm	1,01 %	59,40 Nm	1,01 %	99,20 Nm	0,81 %
maximaler Fehler:		2,56 %		Kalibrierung: IO	
Bestätigung der Kalibrierung nach ISO 6789 Datum, Name, Unterschrift					

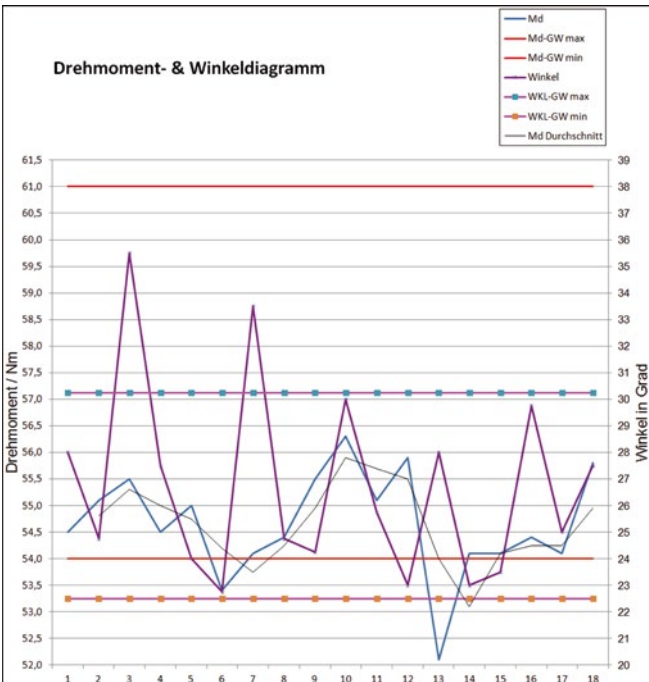

System requirements: up to Win 10,  
Office 95 - 2016

Überprüfung		vom: 26.06.17 bis: 26.06.17	
Werkzeug / (Werkstück)			
Bezeichnung: VK-623	Messprog. Name: MOTOR 623		
Typ: RS25	Datensatz-Kennz.: LAGER 1		
Hersteller: Hudelmaier	Werknummer: 521		
Serien Nr.: 2564482	zuletzt geprüft: -----		
Inventarnummer: 3684423	Kalibrierintervall (Mon.): -----		
Einsatzort: Ulm	nächste Prüfung: -----		
Messmittel			
Sensor		Messgerät:	
Bezeichnung: Drehmomentsensor 1/2"		Bezeichnung: GMV2	
Typ: DRFN-100-w		Typ: GMV2-2.1.1.0.000	
Hersteller: ETH		Hersteller: ETH	
Toleranz: 0,15%		Toleranz: 0,30%	
Serien Nr.: 625735845		Serien Nr.: 625736762	
Inventarnummer: 75-5567		Inventarnummer: 75-5568	
Kalibrierung gültig bis: 01.08.18		Kalibrierung gültig bis: 31.08.19	
Par.-Nr.: 3	von DS: 1	bis DS: 3	Datensatzlänge: 6
Anzahl Datensätze: 3		Anzahl n: 18	
Drehmoment		Winkel	
Mittelwert Xquer:	54,661 Nm	Mittelwert Xquer:	26,69 Grad
Bereich R:	4,200 Nm	Bereich R:	12,75 Grad
Max:	56,300 Nm	Max:	35,50 Grad
Min:	52,100 Nm	Min:	22,75 Grad
Standardabw. (δ):	0,972 Nm	Standardabw. (δ):	3,55 Grad
±3 δ:	2,917 Nm	±3 δ:	10,64 Grad
Sigma (s):	1,001 Nm	Sigma (s):	3,65 Grad
±3 s / %:	3,002 / ± 5,49%	±3 s / %:	10,95 / ± 41,02%
Soll-Drehmoment:		Soll-Winkel:	
Grenzwert max:	61,000 Nm	Grenzwert max:	30,25 Grad
Grenzwert min:	54,000 Nm	Grenzwert min:	22,50 Grad
Anzahl > GWmax / %:	0 0,00%	Anzahl > GWmax / %:	2 11,11%
Anzahl < GWmin / %:	2 11,11%	Anzahl < GWmin / %:	0 0,00%
Cm/Cp:	1,2	Cm/Cp:	0,4
Cmk/Cpk:	0,2	Cmk/Cpk:	0,3
<b>Gesamt</b>			
Anzahl IO / %:	14 77,78%	Cpk gefordert:	1,0
Anzahl NIO / %:	4 22,22%	Status:	NIO

Prüfprotokoll Drehmomentschlüssel			
Sensor			
Fabrikat:	ETH	Serien Nr.:	7010xxxx
Typ:	DRT x	Inventarnummer:	0815
Geprüft Datum:	11. Jun. 17	Toleranz:	≤ 0,15 %
Prüfintervall:	1 Jahr	nächste Prüfung:	11. Jun. 18
Messgerät			
Fabrikat:	ETH	Serien Nr.:	7010xxxy
Typ:	GMV2 (aktiv)	Inventarnummer:	0816
Geprüft Datum:	24. Jan. 17	Toleranz:	≤ 0,3 % ± 2 Digit
Prüfintervall:	1 Jahr	nächste Prüfung:	24. Jan. 18
Drehmomentschlüssel			
Hersteller:	Hauruck		
Artikelbezeichnung:	Drehmomentschlüssel		
Serien Nr.:	4711		
Inventarnummer:	123456		
Drehmomentbereich:	20 - 100 Nm		
Skaleneinteilung:	5 Nm		
Toleranz:	3%		
Messwerte		Ergebnisse	
	75,00	Mittelwert:	75,04
1. Prüfung	75,20	Abweichung:	0,05%
2. Prüfung	75,80	+/- 3 Sigma:	1,55
3. Prüfung	74,80		
4. Prüfung	74,40		
5. Prüfung	75,00		

## Datasheet

### Supply and Display Unit

# ValueView 291-1

### for active torque transducers



- Resolution 24 bit
- Sampling rate up to 50 measurements / s
- Permanent min / max display
- tare function
- Sensor supply
- +/- full scale input
- Peak value measurement

The supply and display unit ValueView gives you in connection with ETH-torque transducers a possibility to show torque values in various manner for a reasonable price. In the standard operating mode "momentary value" you can read the last measured value alternatively the display can be set to "maximum value" or "minimum value". The time of taking a reading and the time of the display-cycle can be programmed.

On all operating modes a tara-function is available With the +/- full-scale-input it is also possible to show the direction of the measured torque. On displaying of four programmable switching points you can supervise the compliance of set threshold values. Special versions for passive transducers and for display of speed are available on demand.

## Technical Specifications

Supply Voltage:	115 – 230 VAC ± 10 % (50 - 60 Hz) mains voltage
Sensor feeding for torque transducers:	12V DC / 500 mA
<b>Input</b>	
Input Sensitivity:	0 to ± 5 V; 0 to ± 10 V
Input resistor:	approx. 10 MΩ
<b>Signal output</b>	
Torque:	looped through transducer
Speed:	looped through transducer
<b>Connection</b>	
Input: (12 polig)	backside by round plug
Output: (7-polig)	backside by round plug
<b>Signal processing</b>	
Measuring time:	0,02 - 10,00 sec
Measuring rate:	max. 50 Measurements / second
Rise time 0 - 100 %:	0,5 ms
Peak value measurement by pulse extension:	20 ms ≈ 98 % ; 100 ms ≈ 90 % (with two consecutive 5 ms pulses)
Delay to output „0“:	100 - 0 % max. 3 s
<b>Accuracy</b>	
Measurement error:	≤ 0,02 % ± 2 digit
Temperature drift:	50 ppm/K
<b>Indication</b>	
Display:	5 digits; LED with 7 segments, 14mm high indication, red
Overflow:	of 4 transversal bars
Display torque range	-9999 ... 99999 Comma freely selectable
<b>Ambient conditions</b>	
Working temperature:	0 to +50 °C
Storage temperature:	-20 to +80 °C
Internal protection:	IP40
Dimensions:	166 x 80 x 200 mm (B x H x T)
Weight:	1200 g

### Connections on the rear side:



### Ordering Code:

Valueview291-1

### Available Accessories:

Cables,  
Torque transducer

**Further options on request!**



## Datasheet

### Supply and Display Unit

# ValueView 291-1-003

for active torque transducers  
with torque and speed display



- 24 bit resolution
- up to 50 measurements per second
- permanent min/max-display
- Tara-function
- Sensorfeeding
- +/- Fullscale-input
- Peak value measurement
- Speed measurement up to 10.000 rpm with 1 decimal place  
over 10.000 U/min without decimal place

The supply and display unit ValueView gives you in connection with ETH-torque transducers a possibility to show torque values in various manner for a reasonable price. In the standard operating mode "momentary value" you can read the last measured value alternatively the display can be set to "maximum value" or "minimum value". The time of taking a reading and the time of the display-cycle can be programmed. On all operating modes a tara-function is available with the +/- full-scale-input it is also possible to

show the direction of the measured torque. On displaying of four programmable switching points you can supervise the compliance of set threshold values. Special versions for passive transducers and for display of speed are available on demand.

## Technical Specifications

Supply Voltage:	230 VAC $\pm$ 10 % (50 - 60 Hz) by connector
Sensor supply for torque transducer:	12V DC / 500 mA
Input	
Input sensitivity:	0 to $\pm$ 5 V; 0 to $\pm$ 10 V;
Input resistance:	10 M $\Omega$
Signal output	
Torque:	Looped through the transducer
Speed:	Looped through the transducer
Connection	
Input: (12 pin)	Backside by round plug
Output: (7-pin)	Backside by round plug
Signal processing	
Measuring time: Torque	0,02 - 10,00 sec.
Speed	0,1 - 10,00 sec.
Measuring rate:	max. 50 measurements / second
Rise time 0 - 100 %:	0,5 ms
Peak value measurement by pulse extension:	20 ms $\approx$ 98 % ; 100 ms $\approx$ 90 % (two consecutive 5 ms pulses)
Delay to output „0“:	100 - 0 % max. 3 s
Accuracy	
Measurement error: Torque	$\leq$ 0,02 % $\pm$ 2 Digit
Speed	$\leq$ 0,05 % $\pm$ 1 Digit
temperature drift:	50 ppm/K
Display	
Display:	4.5 digits; Seven-segment LED, 14 mm, red
Overflow:	Horizontal bar above
Display area: Torque	-9999 Comma freely selectable
Speed	9999,9 U/min or 99999 U/min
Environmental conditions	
Working temperature:	0 to + 50 °C
Storage temperature:	-20 to + 80 °C
Internal protection:	IP40
Dimensions:	185 x 148 x 208 mm (B x H x T)
Weight:	1620 g

### Connections on the rear side:



### Order code:

Valueview291-1-003

### Available options:

Cables,  
Torques

**Further options on request!**

## Chi siamo

Fin dal 1991 siamo fornitori primari delle più importanti industrie, laboratori e Centri di Ricerca Italiani, sia privati che pubblici.

Instrumentation Devices si occupa di sensori, strumenti di misura, sistemi di controllo, acquisizione e analisi dei segnali. Proponiamo quanto di più funzionale ed efficace sia oggi disponibile in questo campo.

Le aziende che rappresentiamo e i prodotti che distribuiamo sono leader del settore e sono il risultato di un'accurata e costante selezione che garantisce elevata qualità e affidabilità ed un'elevata efficienza nella sperimentazione e nel collaudo.





Sensori,  
strumenti  
e sistemi  
di misura

**Instrumentation Devices Srl**

Via Acquanera 29  
22100, Como (CO) - Italien  
PI 02053410136

[info@instrumentation.it](mailto:info@instrumentation.it)

Tel +39.031.52.53.91 - Fax +39.031.507.984

© ETH-messtechnik gmbh

Specification changes, typing and printing errors reserved.

No liability for technical and typographical errors.  
Changes in the sense of technical progress  
can be made without notice.